

1. MECHANICAL DIMENSION

Product Dimension

Unit:mm	General Tolerance :	X.X : ± 0.38
		X.XX : ± 0.20

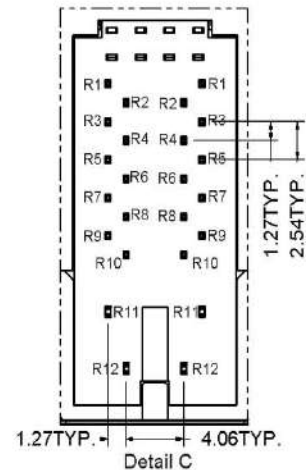
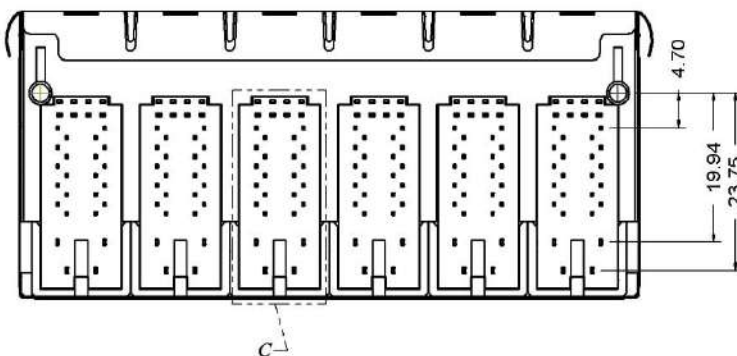
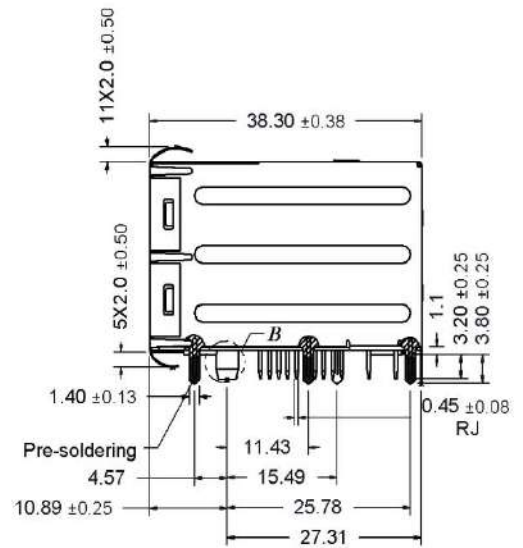
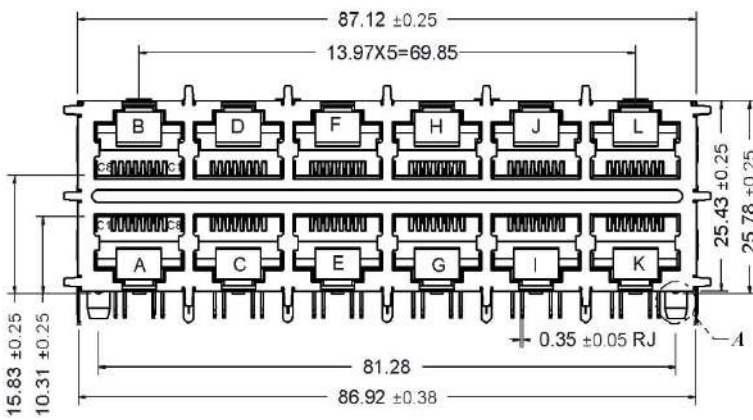
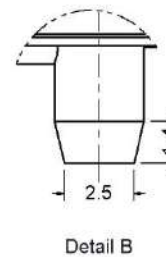
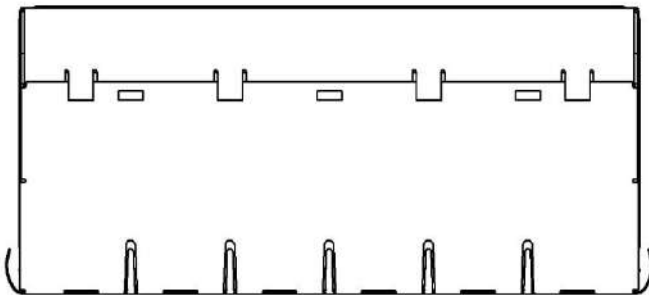
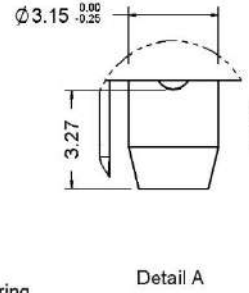
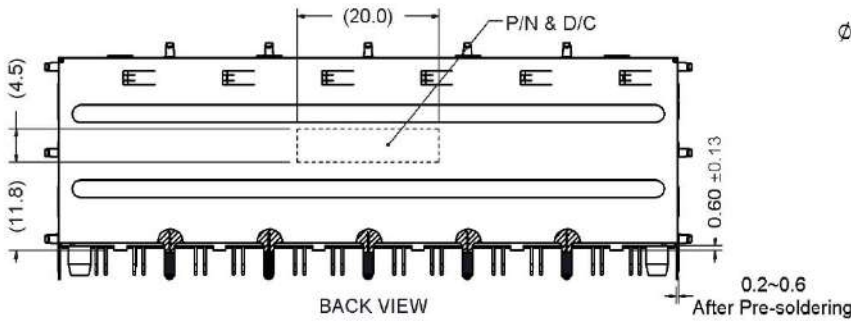

Recommended PCB Layout. Component side of board

All dimension units are "mm".

All dimension tolerances are ±0.05mm unless otherwise specified.

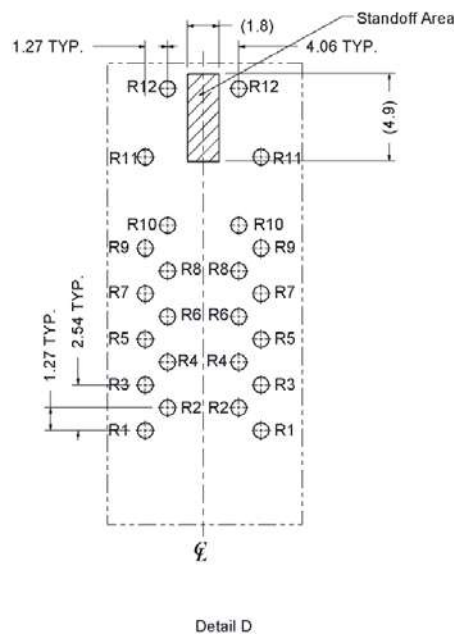
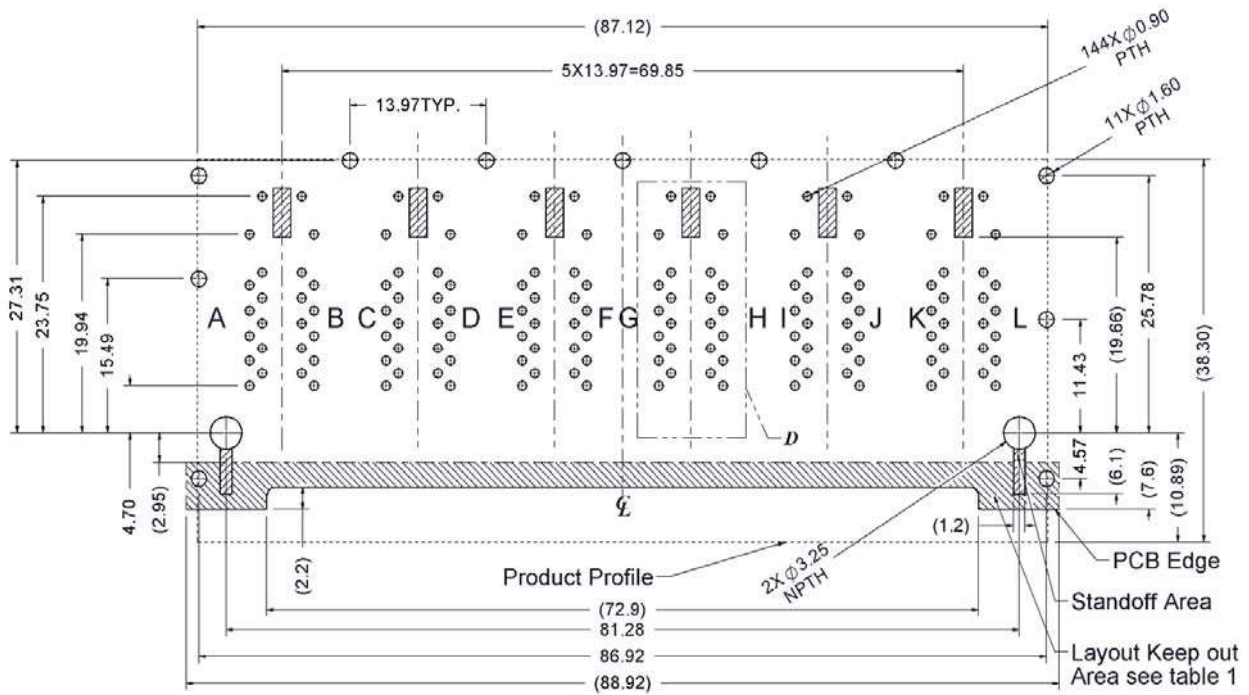
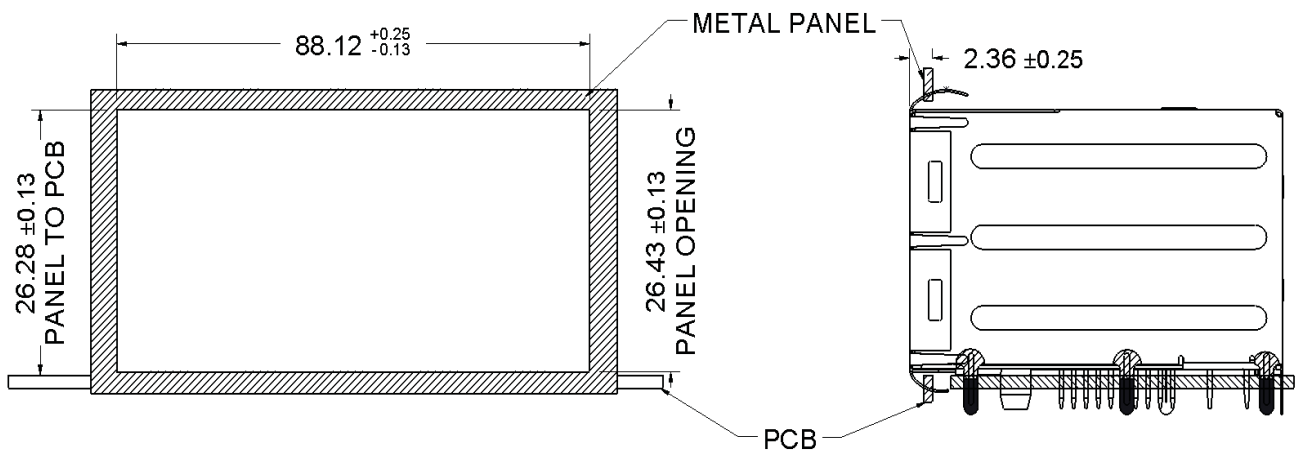

Table1

Layout / Layer	Trace	component	Grounding	Test Point	Via Hole	PTH	NPTH
Component side	X	X	O	X	X	X	O
Inner layer	O	NA	O	NA	O	X	
Bottom side	O	O	O	O	O	X	O

X--Forbid; O--OK; NA--Not Applicable.

## Recommended Panel cutout



## 2. Packing Information

9 pcs finished goods per tray

5 trays (45 pcs finished goods) per inner box

4 Inner boxes (180 pcs finished goods) per master carton

### 3. Standard RJ45 Plug Specification

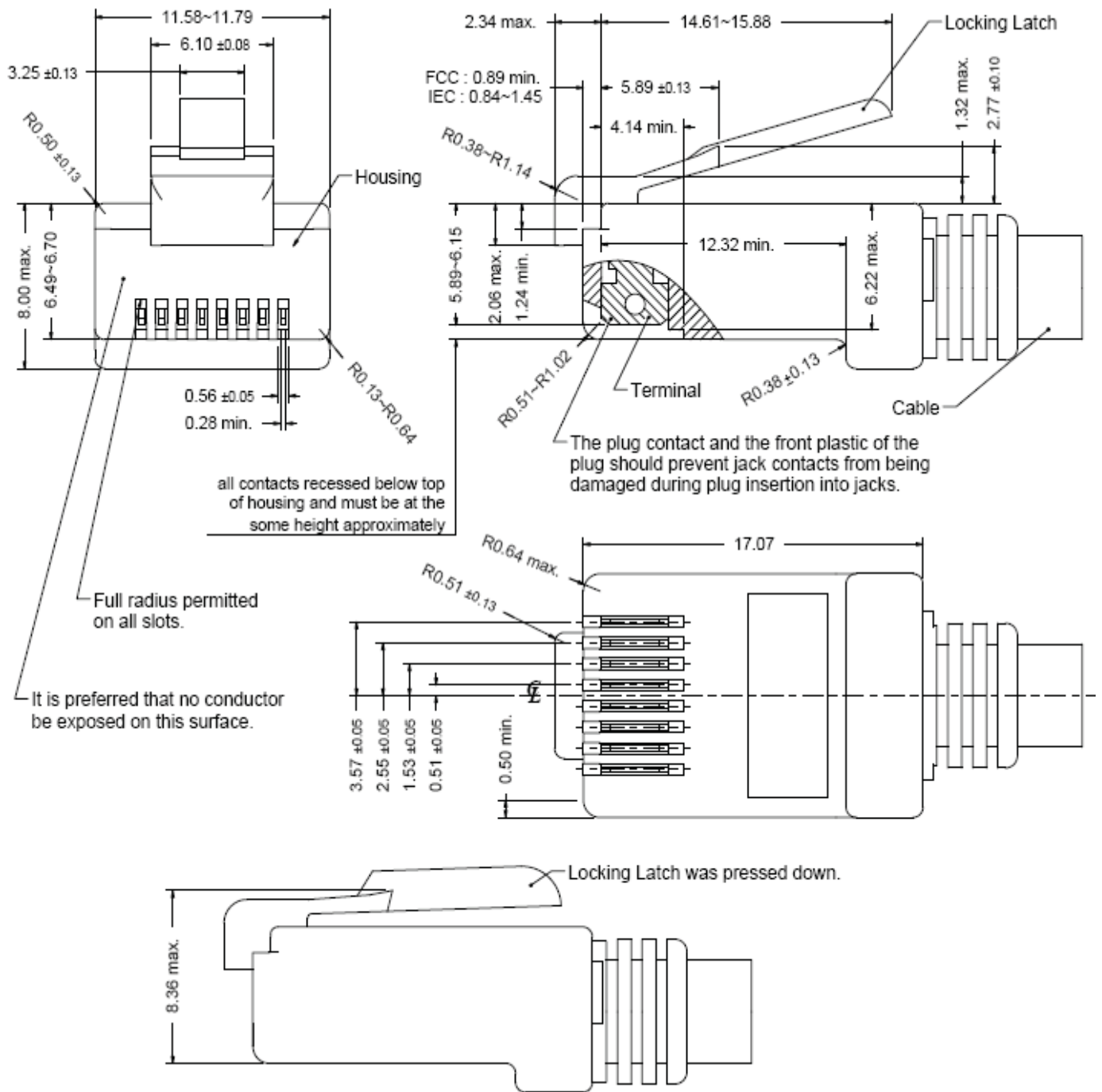

- All dimensions follow :  
FCC subpart F, 68,500, Figure (C)(2)(i) & (C)(2)(ii) & (C)(3)(i)  
IEC 60603-7
- All plugs must be meeting the requirements of plug Go & No-Go gauge.  
Gauge follow : FCC subpart F, 68,500, Figure (C)(4)(i) & (C)(5)(i)
- There must be no damage to Housing and Locking Latch.
- There must be no nicks and cuts in cable.
- Durability : 750 cycles generally

#### 4. REQUIREMENTS

##### Design and Construction

Product shall be of design, construction and physical dimensions specified on applicable.

##### Material

Terminal Parts ( Underplating : 50 $\mu$ "min. Nickel overall )

RJ Terminal : YCUT-FX-H, Thickness=0.30mm

Finish : Contact Area : 6 $\mu$ " min. Gold

Input Terminal : Brass, Thickness=0.35mm

Finish : 100 $\mu$ " min. Bright Tin

Case Terminal : Brass, Thickness=0.30mm

Finish : 100 $\mu$ " min. Bright Tin

Plastic Parts <UL94V-0>

Housing : PA6T, Black

Case : PA6T, Black

Spacer : PA6T, Black

Terminal Cover: PA6T, Black

Terminal Base : PA6T, Black

Insert : PA6T, Black

Cover : PA6T, Black

##### Shield Parts

Front Shield : Stainless, Thickness=0.20mm, unplating

Back Shield : Stainless, Thickness=0.20mm, Pre-soldering

## 5. Operating and Storage Temperature

Operating Temperature : 0°C to +70°C

Storage Temperature : -40°C to +85°C

## 6. RJ45 specifications

Insulation Resistance : 500MΩ min.

Insertion force with the latch depressed : 20N max.

Removal force with the latch depressed : 20N max.

Locking Force of Plug Latch : 50N min. @ 60+/-5 sec.

Durability : 2500 cycles

## 7. Performance and Test Description

Product is designed to meet electrical, mechanical and environmental performance requirements specified in below table.

All tests are performed at ambient environmental conditions per MIL-STD-1344A and EIA-364 unless otherwise specified.

## 8. Packaging and Packing

All parts shall be packaged and packed to protect against physical damage, corrosion and deterioration during shipment and storage.

# 9. ELECTRICAL CHARACTERISTICS @ 25°C

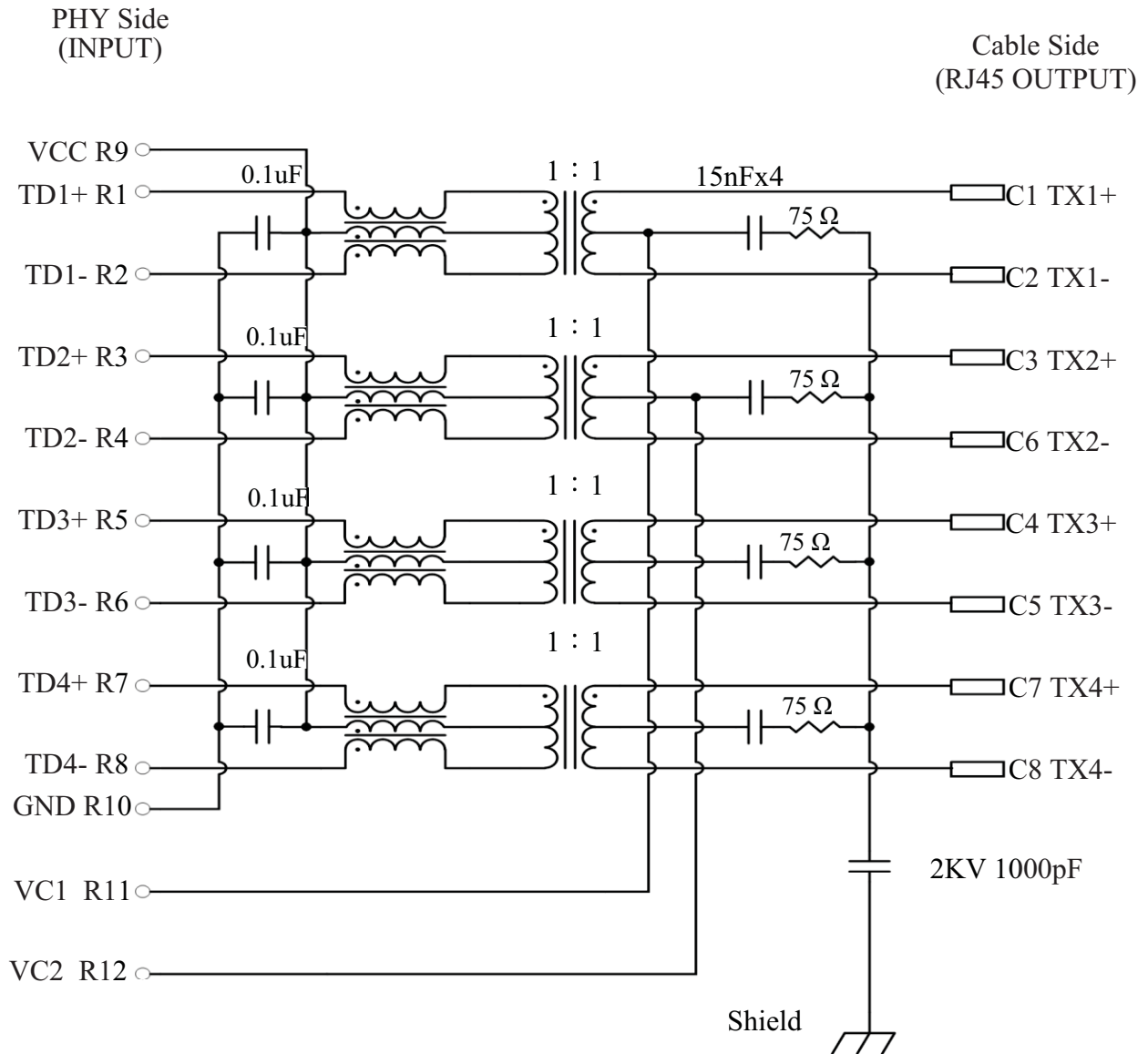

### Transmitter filter & Receiver filter

Type : Balance low pass 100Ω impedance

Insertion loss : 1~100MHz -1.0dB max.

Return loss :	1~30MHz	-18dB min.	load 100Ω
	30~60MHz	-16dB min.	load 100Ω
	60~80MHz	-12dB min.	load 100Ω
	80~100MHz	-10dB min.	load 100Ω

### Common Mode Rejection

@1~100 MHz -30dB min.

### Cross Talk

@ 1~100MHz -30dB min.

### Inductance (OCL) @ 100KHz, 0.1V, 8mA DC BIAS

Input(TD1+,TD1-); (TD2+,TD2-); (TD3+,TD3-); (TD4+,TD4-) : 350 μH min.

### HiPot Test

PHY Side(input) To Cable Side(output) : 1500Vac 60s or 2250Vdc 60s



Balanced DC line current

350mA MAX @57VDC continuous

500mA MAX @57VDC for 200 milliseconds

# 10. WAVE SOLDERING TEMPERATURE PROFILE

Note :

The measuring point for the specified temperature shall be on the soldered part of the lead.

