

1 REACH & RoHS COMPLIANT

6	7	8	
REV.	ECN / DESCRIPTION	BY	DATE
A0	NEW	MQ.Qu	2017.11.20

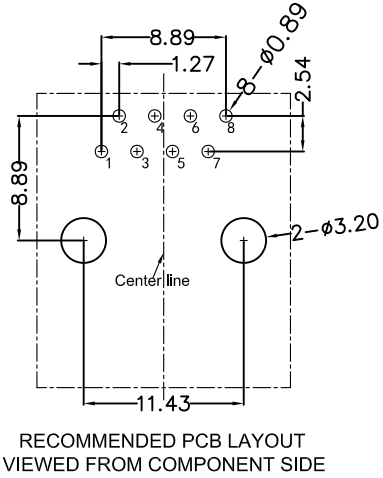
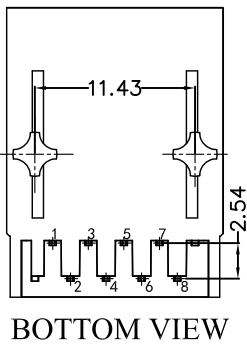
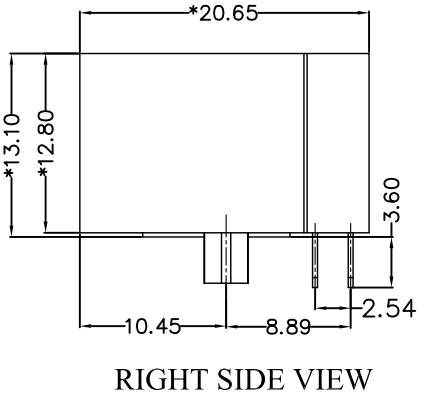
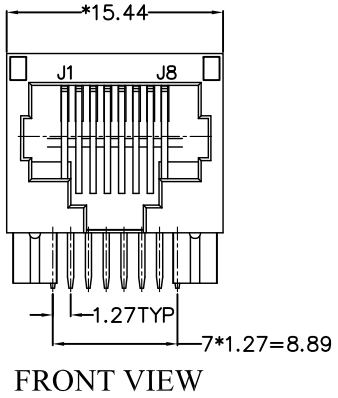

MATERIAL:
 HOUSING: PBT,UL94V-0,BLACK.
 TERMINALS BRACKET: PBT,UL94V-0,BLACK.
 TERMINAL: PHOSPHOR BRONZE C5210,T=0.35MM,
 6U" GOLD PLATING ON CONTACT AREA.

MECHANICAL:
 DURABILITY: 750 CYCLES MIN.
 MATING FORCE: 23N MAX.
 OPERATING TEMPERATURE: -40°C~+85°C.
 STORAGE TEMPERATURE: -40°C~+85°C.
 ALL CRITICAL DIMENSIONS WITH "*"

 东莞市涪程电子科技有限公司
 DONG GUAN FU CHENG ELECTRONIC TECHNOLOGY Co., LTD

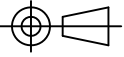
TITLE: TAB-DOWN 1X1 100BASE	SIZE A4	UNITS MM[INCH]	GENERAL TOLERANCES UNLESS SPECIFIED		APPROVED BY: JP.Gong
PART NO.: FCRJ-015DJWDNL	SACLE 1:1	REV A0	x±0.35	x°±3.0°	CHECKED BY: TW.Xu
REMARK:	SHEET 1/3		.x±0.30	.x°±2.0°	DESIGND BY: MQ.Qu
			.xx±0.25	.xx°±1.5°	
			.xxx±0.10	.xxx°±1.0°	

REACH & RoHS
COMPLIANT

REV.	ECN / DESCRIPTION	BY	DATE
A0	NEW	MQ.Qu	2017.11.20

PCB SIDE TO PHY

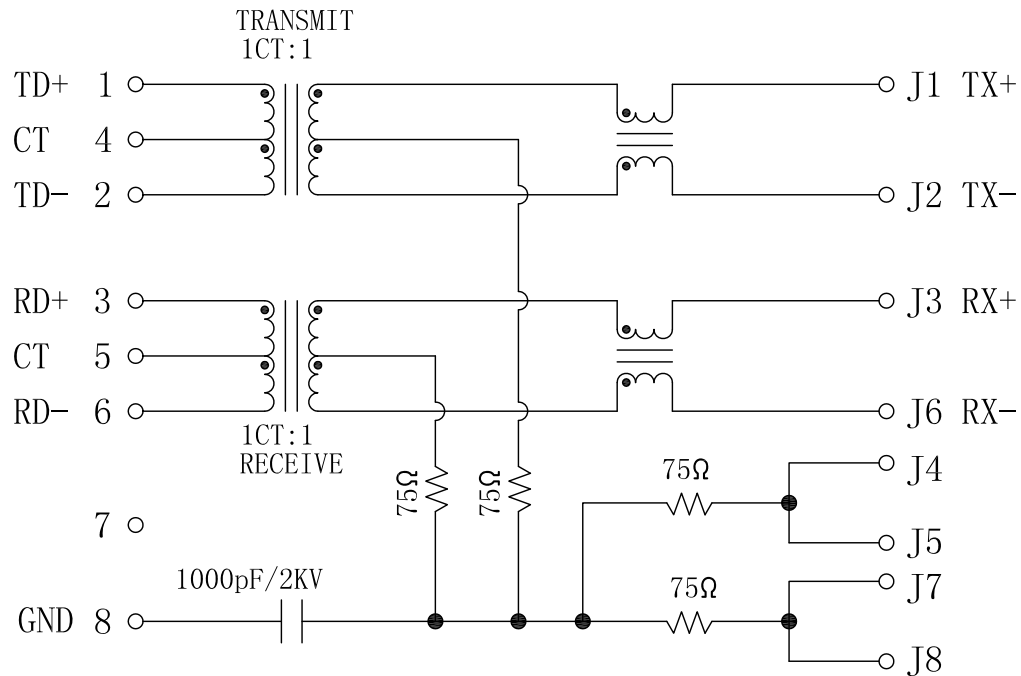

Electrical:

- Turn ratio: 1~2: J1~J2=1CT:1CT(±2%).
3~6: J3~J6=1CT:1CT(±2%).
- OCL: 350uH Min. at 100KHz 100mV 8mA DC.
- Insertion Loss: -1.0 dB Max 1~100MHz.
- Return loss: -20dB Min 1~10MHz;
-16dB Min 10~30MHz.
-12dB Min 30~60MHz.
-10dB Min 60~80MHz.
- Cross talk: -40dB Min 1~30MHz;
-35dB Min 30~60MHz;
-30dB Min 60~100MHz;
- CMR: -35dB Min 1~100MHz;
- Hi-Pot: 1500V AC & 2250V DC
6S 1mA PRI TO SEC



东莞市浚程电子科技有限公司
DONG GUAN FU CHENG ELECTRONIC TECHNOLOGY Co., LTD

TITLE: TAB-DOWN 1X1 100BASE	SIZE A4	UNITS MM[INCH]	GENERAL TOLERANCES UNLESS SPECIFIED		APPROVED BY: JP.Gong
PART NO.: FCRJ-015DJWDNL	SACLE 1:1	REV A0	x±0.35 .x±0.30	x°±3.0° .x°±2.0°	CHECKED BY: TW.Xu
REMARK:	SHEET 1/3		.xx±0.25 .xxx±0.10	.xx°±1.5° .xxx°±1.0°	DESIGN BY: MQ.Qu

REACH & RoHS
COMPLIANT

PROFILE OF WAVE SOLDER

REV.	ECN / DESCRIPTION	BY	DATE
A0	NEW	MQ.Qu	2017.11.20

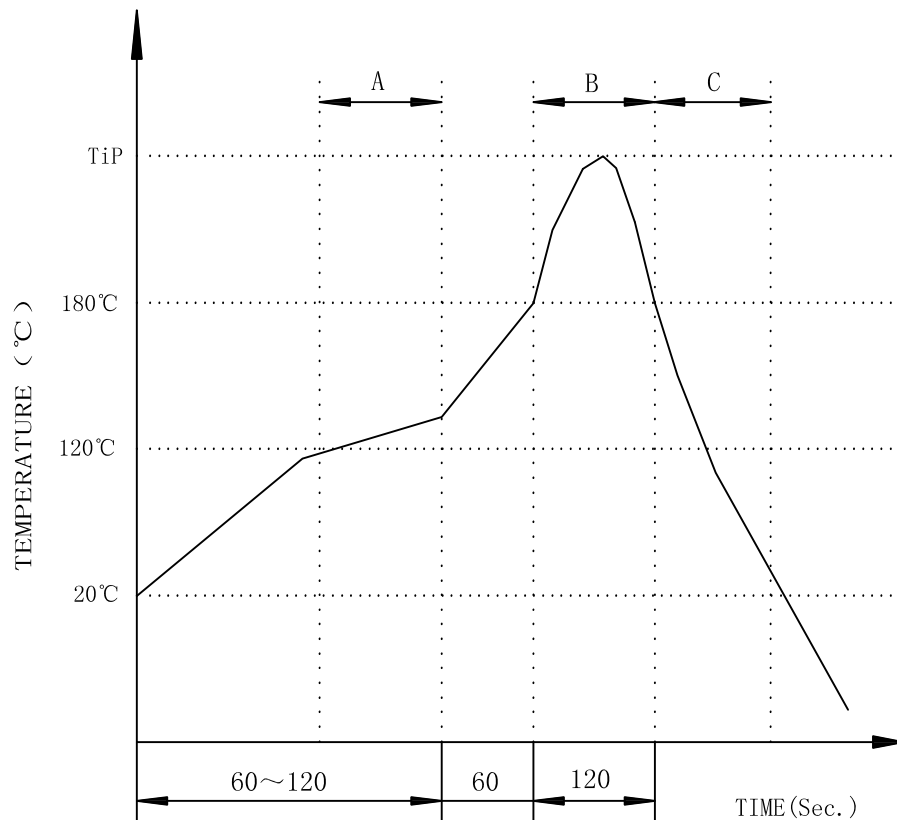

A.Preheating B.Soldering C.Gradual Cooling
 Tip temperature:260±5°C.
 Tip temperature time:5Sec Max.
 Tip melting point of Sn96.5/Ag3/Cu0.5:217°C.

Remarks: after wave soldering, the plastic positioning columns of the product which under the PCB will be slightly melted, but it won't affect its function.

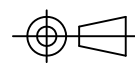
 东莞市涪程电子科技有限公司 DONG GUAN FU CHENG ELECTRONIC TECHNOLOGY Co., LTD	TITLE: TAB-DOWN 1X1 100BASE	SIZE A4	UNITS MM[INCH]	GENERAL TOLERANCES UNLESS SPECIFIED		APPROVED BY: JP.Gong
	PART NO.: FCRJ-015DJWDNL	SACLE 1:1	REV A0	$x \pm 0.35$ $.x \pm 0.30$	$x^\circ \pm 3.0^\circ$ $.x^\circ \pm 2.0^\circ$	CHECKED BY: TW.Xu
	REMARK:	SHEET 1/3		$.xx \pm 0.25$ $.xxx \pm 0.10$	$.xx^\circ \pm 1.5^\circ$ $.xxx^\circ \pm 1.0^\circ$	DESIGND BY: MQ.Qu