

REACH & RoHS  
COMPLIANT

REV.	ECN / DESCRIPTION	BY	DATE
A0	NEW	MQ.Qu	2018.03.24

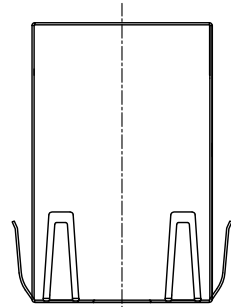

TOP VIEW

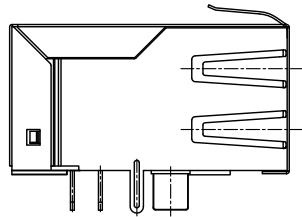

LEFT SIDE VIEW

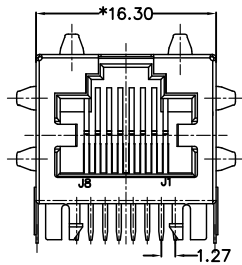

FRONT VIEW

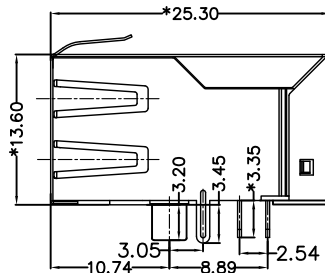

RIGHT SIDE VIEW

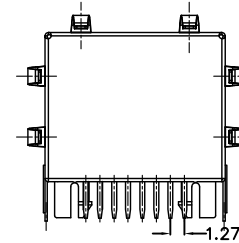

BACK VIEW

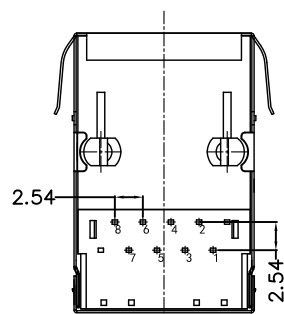

BOTTOM VIEW

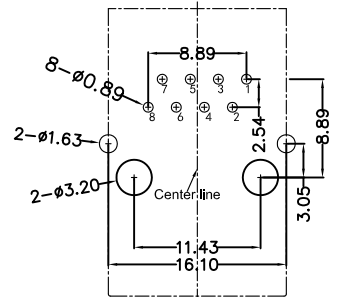

RECOMMENDED PCB LAYOUT  
VIEWED FROM COMPONENT SIDE

**MATERIAL:**

HOUSING : PBT,UL94V-0,BLACK.  
 TERMINALS BRACKET: PBT,UL94V-0,BLACK.  
 SHIELD: C2680,T=0.20MM,NICKEL PLATING ON ALL AREA.  
 TERMINAL: PHOSPHOR BRONZE C5210,T=0.35MM,  
 6U" GOLD PLATING ON CONTACT AREA.

**MECHANICAL:**

DURABILITY : 750 CYCLES MIN.  
 MATING FORCE : 30N MAX.  
 OPERATING TEMPERATURE: -40°C~+85°C.  
 STORAGE TEMPERATURE: -40°C~+85°C.  
 ALL CRITICAL DIMENSIONS WITH "\*"

 东莞市涪程电子科技有限公司  
 DONG GUAN FU CHENG ELECTRONIC TECHNOLOGY Co., LTD

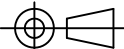
TITLE: TAB-UP 1X1 100BASE	SIZE A4	UNITS MM[INCH]	GENERAL TOLERANCES UNLESS SPECIFIED		APPROVED BY: JP.Gong
PART NO.: FCRJ-060SHWNL	SACLE 1:1	REV A0	x±0.35 .x±0.30	x°±3.0° .x°±2.0°	CHECKED BY: TW.XU
REMARK:	SHEET 1/3		.xx±0.25 .xxx±0.10	.xx°±1.5° .xxx°±1.0°	DESIGND BY: MQ.QU

1 REACH & RoHS COMPLIANT

REV.	ECN / DESCRIPTION	BY	DATE
A0	NEW	MQ.Qu	2018.03.24

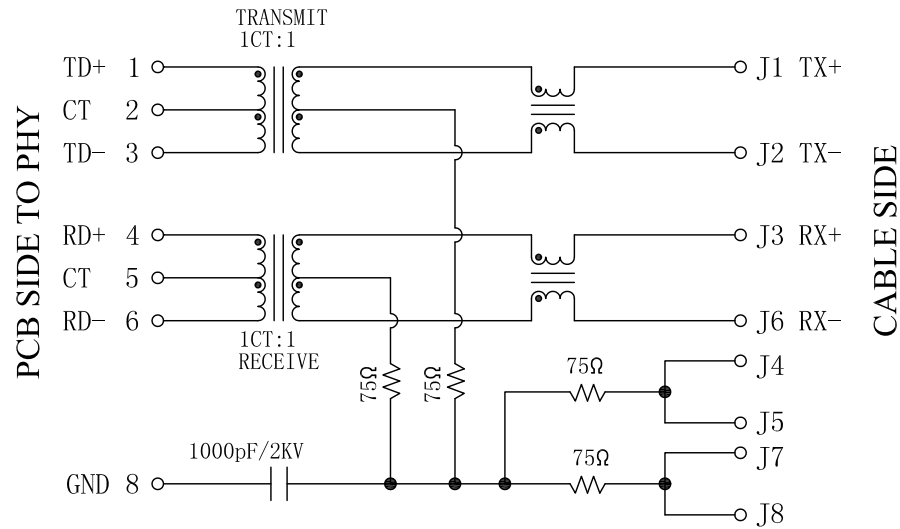

**Electrical:**

- Turn ratio: 1~3: J1~J2=1CT:1CT(±2%).  
4~6: J3~J6=1CT:1CT(±2%).
- OCL: 350uH Min. at 100KHz 100mV 8mA DC.
- Insertion Loss: -1.0 dB Max 1~100MHz.
- Return loss: -20dB Min 1~10MHz;  
-16dB Min 10~30MHz.  
-12dB Min 30~60MHz.  
-10dB Min 60~80MHz.
- Cross talk: -40dB Min 1~30MHz;  
-35dB Min 30~60MHz;  
-30dB Min 60~100MHz;
- CMR: -35dB Min 1~100MHz;
- Hi-Pot: 1500V AC & 2250V DC  
6S 1mA PRI TO SEC

 东莞市涪程电子科技有限公司  
DONG GUAN FU CHENG ELECTRONIC TECHNOLOGY Co., LTD

TITLE: TAB-UP 1X1 100BASE	SIZE A4	UNITS MM[INCH]	GENERAL TOLERANCES UNLESS SPECIFIED		APPROVED BY: JP.Gong
PART NO.: FCRJ-060SHWNL	SACLE 1:1	REV A0	x±0.35	x°±3.0°	CHECKED BY: TW.XU
REMARK:	SHEET 1/3		.xx±0.25	.xx°±1.5°	DESIGND BY: MQ.QU
			.xxx±0.10	.xxx°±1.0°	

REACH & RoHS  
COMPLIANT

# PROFILE OF WAVE SOLDER

REV.	ECN / DESCRIPTION	BY	DATE
A0	NEW	MQ.Qu	2018.03.24

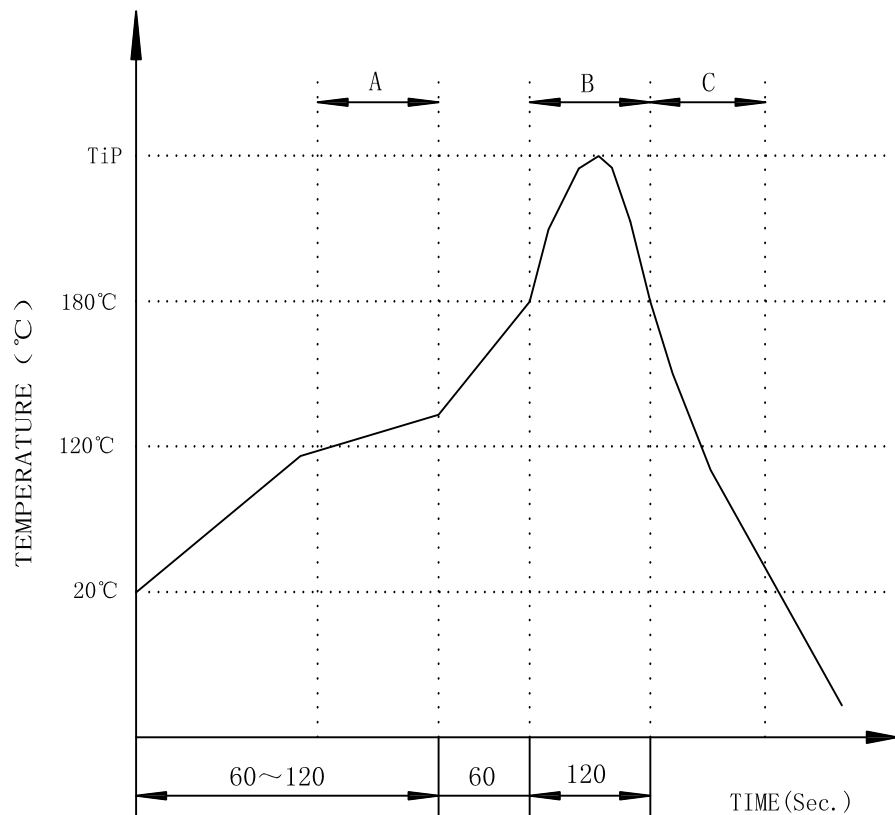

A.Preheating B.Soldering C.Gradual Cooling  
 Tip temperature:260±5°C.  
 Tip temperature time:5Sec Max.  
 Tip melting point of Sn96.5/Ag3/Cu0.5:217°C.

Remarks: after wave soldering, the plastic positioning columns of the product which under the PCB will be slightly melted, but it won't affect its function.

 东莞市涪程电子科技有限公司  
 DONG GUAN FU CHENG ELECTRONIC TECHNOLOGY Co., LTD

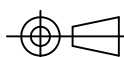
TITLE: TAB-UP 1X1 100BASE	SIZE A4	UNITS MM[INCH]	GENERAL TOLERANCES UNLESS SPECIFIED		APPROVED BY: JP.Gong
PART NO.: FCRJ-060SHWNL	SACLE 1:1	REV A0	x±0.35 .x±0.30	x°±3.0° .x°±2.0°	CHECKED BY: TW.XU
REMARK:	SHEET 1/3		.xx±0.25 .xxx±0.10	.xx°±1.5° .xxx°±1.0°	DESIGND BY: MQ.QU