

REACH & RoHS  
COMPLIANT

REV.	ECN / DESCRIPTION	BY	DATE
A0	NEW	GQ,Chen	2018.07.24

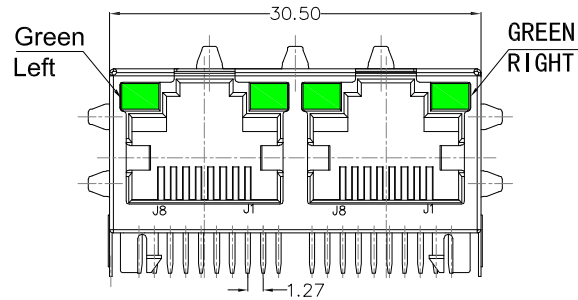

FRONT VIEW

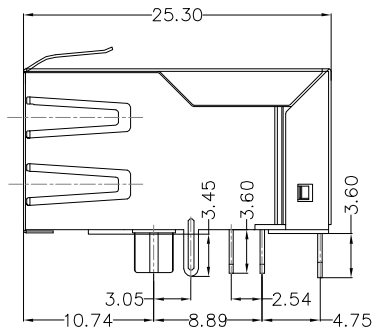

RIGHT SIDE VIEW

**MATERIAL:**

HOUSING: PBT,UL94V-0,BLACK.  
 TERMINALS BRACKET: PBT,UL94V-0,BLACK.  
 SHIELD: C2680,T=0.20MM,NICKEL PLATING ON ALL AREA.  
 TERMINAL: PHOSPHOR BRONZE C5210,T=0.35MM,  
 6U" GOLD PLATING ON CONTACT AREA.

**MECHANICAL:**

DURABILITY: 750 CYCLES MIN.  
 MATING FORCE: 23N MAX.  
 OPERATING TEMPERATURE: 0°C~+70°C.  
 STORAGE TEMPERATURE: -40°C~+85°C.  
 ALL CRITICAL DIMENSIONS WITH "\*\*"

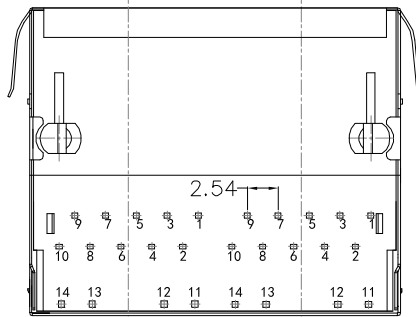

BOTTOM VIEW

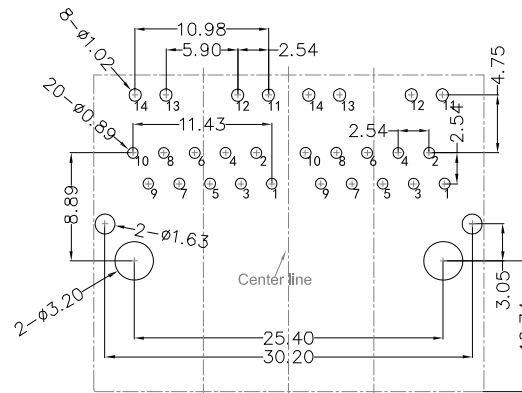

RECOMMENDED PCB LAYOUT  
VIEWED FROM COMPONENT SIDE

 东莞市涪程电子科技有限公司  
 DONG GUAN FU CHENG ELECTRONIC TECHNOLOGY Co., LTD

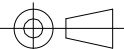
TITLE: TAB-UP 1X2 1000BASE	SIZE A4	UNITS MM[INCH]	GENERAL TOLERANCES UNLESS SPECIFIED		APPROVED BY: JP.Gong
PART NO.: FCRJ45-312Q018DB3A4D	SACLE 1:1	REV A0	$x \pm 0.35$	$x^\circ \pm 3.0^\circ$	CHECKED BY: TW.Xu
REMARK:	SHEET 1/1		$.xx \pm 0.25$	$.xx^\circ \pm 1.5^\circ$	DESIGN BY: GQ,Chen
			$.xxx \pm 0.10$	$.xxx^\circ \pm 1.0^\circ$	

REACH & RoHS  
COMPLIANT

REV.	ECN / DESCRIPTION	BY	DATE
A0	NEW	GQ,Chen	2018.07.24

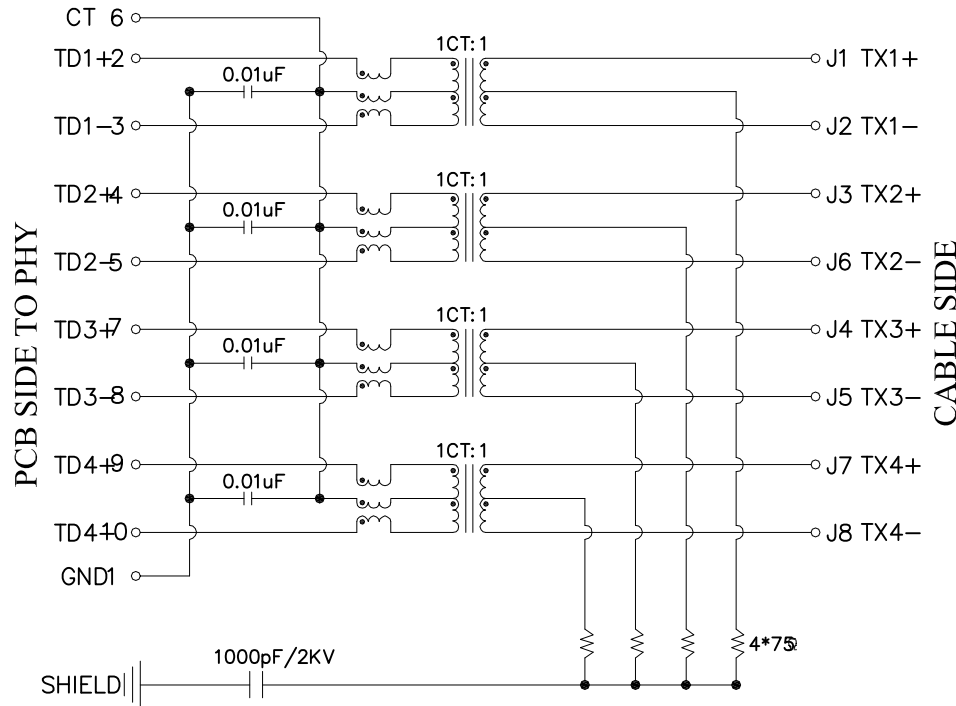

**Electrical:**

- Turn ratio: 2~3: J1~J2=1CT:1CT(±2%).  
4~5: J3~J6=1CT:1CT(±2%).  
7~8: J4~J5=1CT:1CT(±2%).  
9~10: J7~J8=1CT:1CT(±2%).
- OCL: 350uH Min. at 100KHz 100mV 8mA DC.
- Insertion Loss: -1.0 dB Max 1~100MHz.
- Return loss: -20dB Min 1~10MHz;  
-16dB Min 10~30MHz.  
-12dB Min 30~60MHz.  
-10dB Min 60~80MHz.
- Cross talk: -40dB Min 1~30MHz;  
-35dB Min 30~60MHz;  
-30dB Min 60~100MHz;
- CMR: -30dB Min 1~100MHz;
- Hi-Pot: 2250V DC 6S 1mA PRI TO SEC

**LED Specification**

Standard LED Color	LED Wavelength	Foward(A)	Foward(V)
Green	568nm	20mA	1.85-2.45V

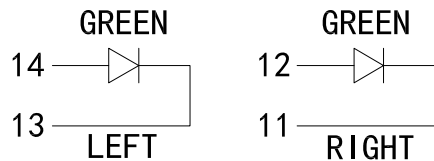

<b>TITLE:</b> TAB-UP 1X2 1000BASE	<b>SIZE</b> A4	<b>UNITS</b> MM[INCH]	<b>GENERAL TOLERANCES</b> UNLESS SPECIFIED		<b>APPROVED BY:</b> JP.Gong
<b>PART NO.:</b> FCRJ45-312Q018DB3A4D	<b>SACLE</b> 1:1	<b>REV</b> A0	x±0.35	x°±3.0°	<b>CHECKED BY:</b> TW.Xu
<b>REMARK:</b>	<b>SHEET</b> 1/1		.xx±0.25	.xx°±1.5°	<b>DESIGN BY:</b> GQ,Chen
			.xxx±0.10	.xxx°±1.0°	

东莞市涪程电子科技有限公司  
DONG GUAN FU CHENG ELECTRONIC TECHNOLOGY Co., LTD

REACH & RoHS  
COMPLIANT

# PROFILE OF WAVE SOLDER

REV.	ECN / DESCRIPTION	BY	DATE
A0	NEW	GQ,Chen	2018.07.24

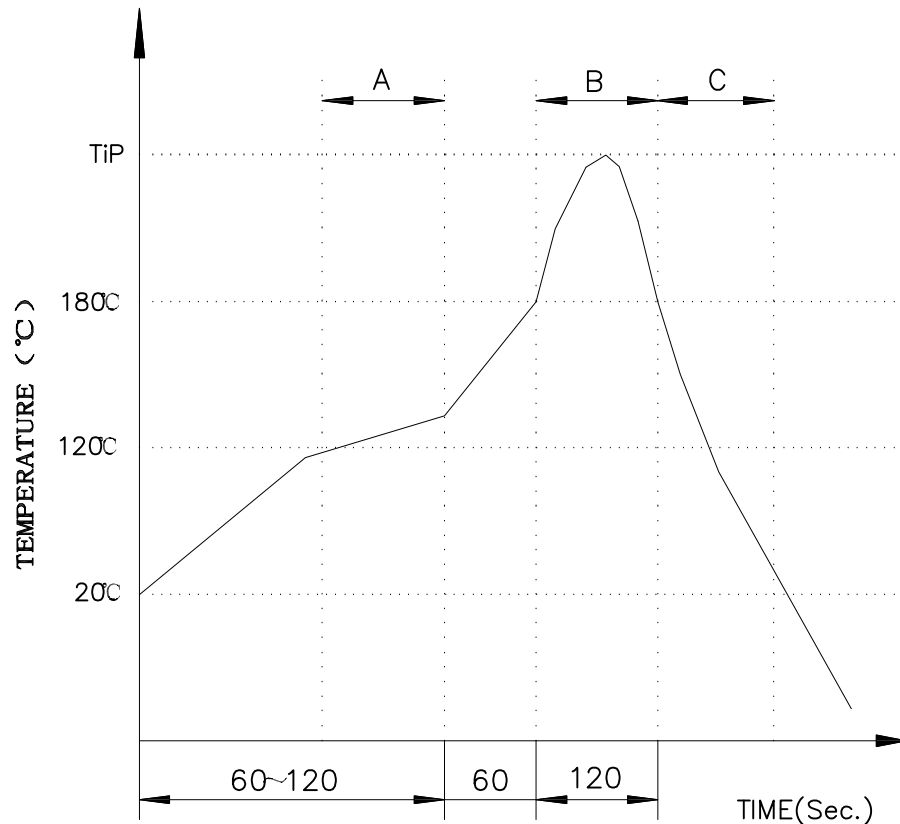

A.Preheating B.Soldering C.Gradual Cooling  
 Tip temperature:260±5°C.  
 Tip temperature time:5Sec Max.  
 Tip melting point of Sn96.5/Ag3/Cu0.5:217°C.

Remarks: after wave soldering, the plastic positioning columns of the product which under the PCB will be slightly melted, but it won't affect its function.

 东莞市浚程电子科技有限公司  
 DONG GUAN FU CHENG ELECTRONIC TECHNOLOGY Co., LTD

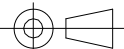
TITLE: TAB-UP 1X2 1000BASE	SIZE A4	UNITS MM[INCH]	GENERAL TOLERANCES UNLESS SPECIFIED		APPROVED BY: JP.Gong
PART NO.: FCRJ45-312Q018DB3A4D	SACLE 1:1	REV A0	x±0.35 .x±0.30	x°±3.0° .x°±2.0°	CHECKED BY: TW.Xu
REMARK:	SHEET 1/1		.xx±0.25 .xxx±0.10	.xx°±1.5° .xxx°±1.0°	DESIGND BY: GQ,Chen