

SMA series

RF Coaxial Connector

FEATURES

- Small size and wide frequency band
- Excellent mechanical and electrical performance, high reliability
- Suitable for fields such as microwave communication, aerospace, navigation and microwave measurement equipment

TECHNICAL PARAMETER

Temperature: -65~+165°C

Impedance: 50Ω

Frequency: 0~12.4GHz bx cable

0~18GHz semi rigid and semi flexible cable

VSWR: $\leq 1.15 + 0.02F$ bx cable

$\leq 1.10 + 0.02F$ semi rigid and semi flexible cable

Insulation resistance: $\geq 5000M\Omega$

Dielectric strength: 1000V(rms)

Operating Voltage: 330V (rms)

Contact resistance: Center contact: $< 3m\Omega$;

Outer contact: $< 2m\Omega$

Mechanical endurance: 500 ops

IMPLEMENTATION CRITERIA

IEC 60169-15 GB/T 11319-89



INTERFACE DIMENSIONS

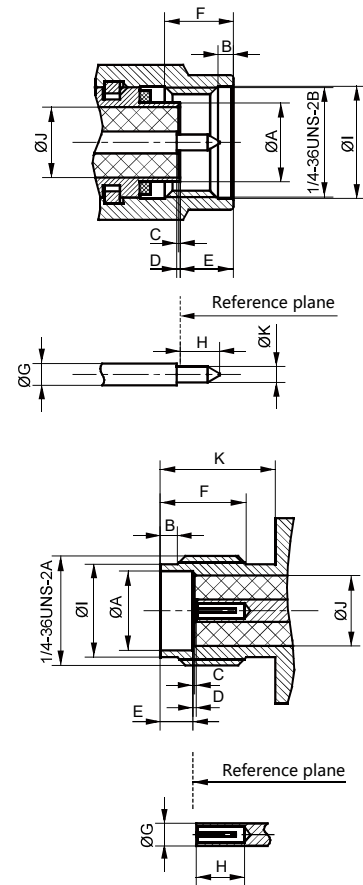

Male Connector

	Min(mm)	Max(mm)
A	/	4.59
B	0.38	1.14
C	-0.18	+0.05
D	0.00	/
E	/	3.43
F	2.54	/
G	Ø1.27 Nominal value	
H	/	2.54
I	6.35	/
J	/	4.13
K	0.902	0.935

Female Connector

	Min(mm)	Max(mm)
A	4.60	4.67
B	0.38	1.14
C	-0.05	0.18
D	0.00	0.41
E	1.88	1.98
F	4.32	/
G	Ø1.27 Nominal value	
H	2.92	/
I	5.28	5.49
J	/	4.178
K	5.54	/

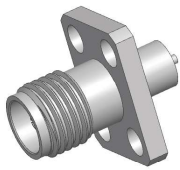

SMA-KFD-6

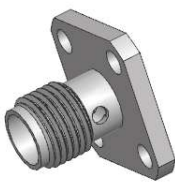
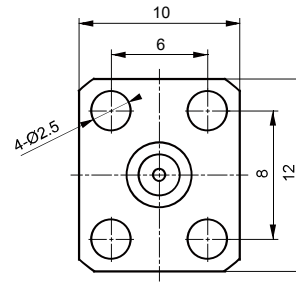
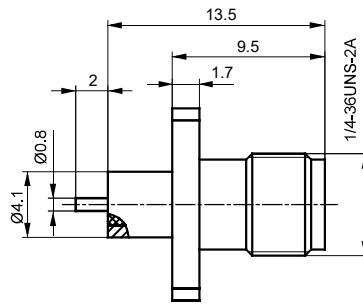

SMA-KFD-13

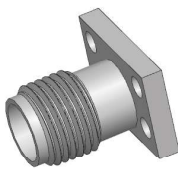
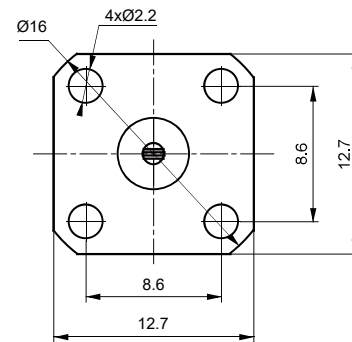
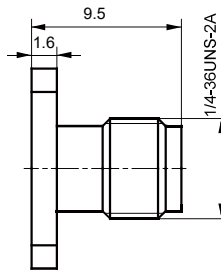

SMA-KFD-17

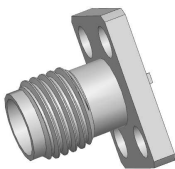
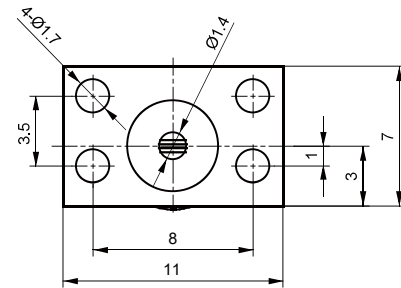
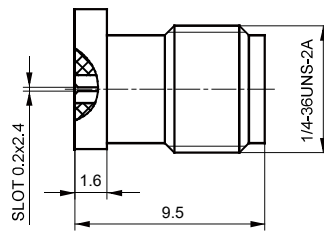

SMA-KFDG-19

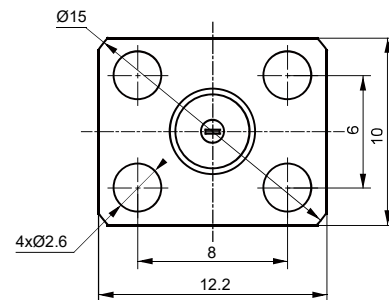
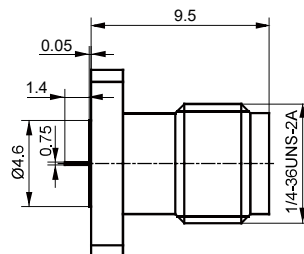

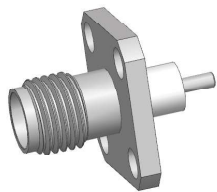

SMA-KFD4-3

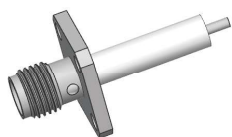
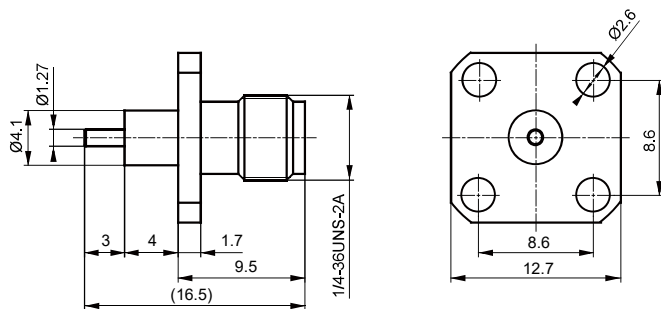

SMA-KFDG-7

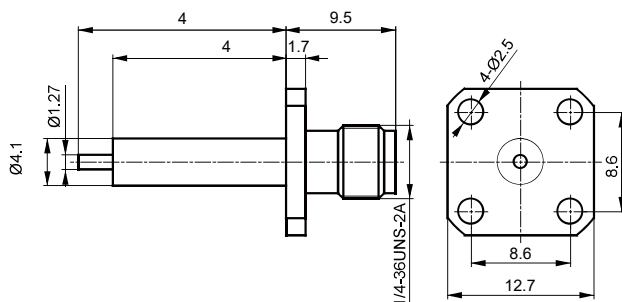

Type	Cable	Notes
SMA-KFDG-7	/	stainless steel

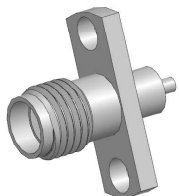

SMA-KFD-50

PC BOARD LAYOUT

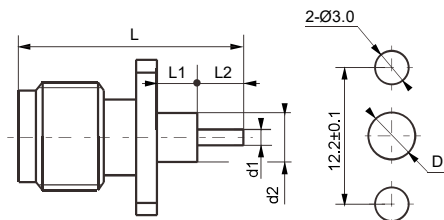

Type	L	L1	L2	d1	d2	D
SMA-KFD-50	27.6	15	3	Ø1.3	Ø4.1	Ø4.2
SMA-KFD-51	14.8	3.2	2	Ø1.3	Ø4.1	Ø4.2

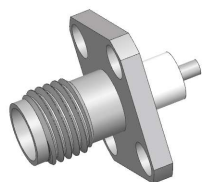

SMA-KFD-52

PC BOARD LAYOUT

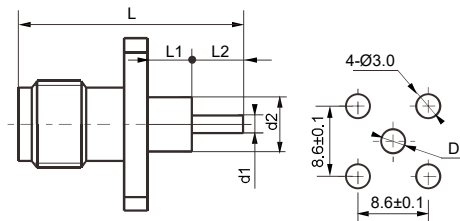

Type	L	L1	L2	d1	d2	D
SMA-KFD-52	15.6	4	2	Ø1.3	Ø4.1	Ø4.2
SMA-KFD-53	20.6	9	2	Ø1.3	Ø4.1	Ø4.2

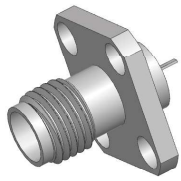

SMA-KFD-55

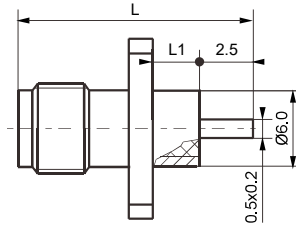

PC BOARD LAYOUT

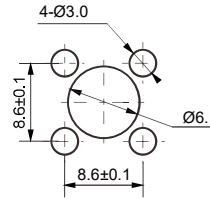

Type	L	L1
SMA-KFD-55	14.5	2.4
SMA-KFD-56	15.3	3.2
SMA-KFD-57	16.9	4.8
SMA-KFD-58	16.1	4

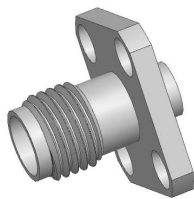

SMA-KFD-61

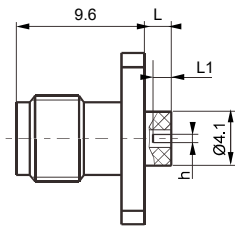

PC BOARD LAYOUT

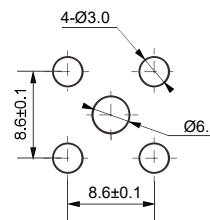

Type	L	L1	h
SMA-KFD-61	2.0	2.0	0.4
SMA-KFD-62	3.0	2.5	0.2

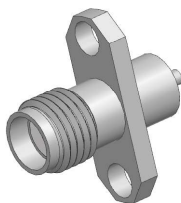

SMA-KFD-64

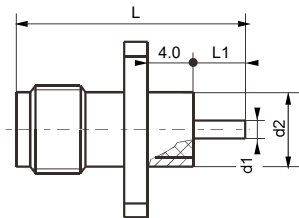

PC BOARD LAYOUT

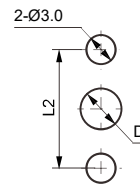

Type	L	L1	L2	d1	d2	D
SMA-KFD-64	15.6	4	12.2±0.1	Ø1.3	Ø6.0	Ø6.1
SMA-KFDG-64	15.6	9	12.2±0.1	Ø1.3	Ø6.0	Ø6.1

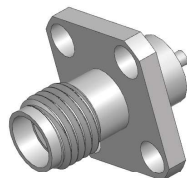

SMA-KFD-65

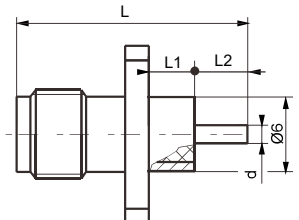

PC BOARD LAYOUT

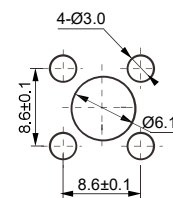

Type	L	L1	L2	d
SMA-KFD-65	15.6	4.0	2.0	Ø1.3
SMA-KFD-66	15.8	3.2	3.0	Ø1.3

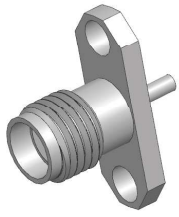

SMA-KFD-67

PC BOARD LAYOUT

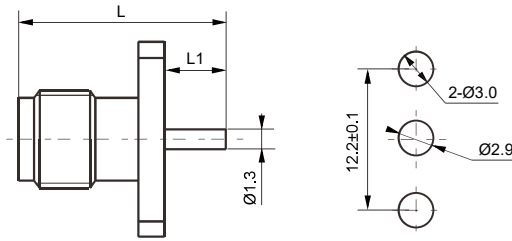

Type	L	L1
SMA-KFD-67	13.6	4.0
SMA-KFD-68	12.1	2.5

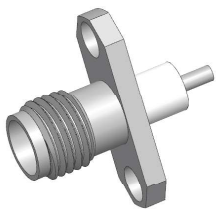

SMA-KFD-69

PC BOARD LAYOUT

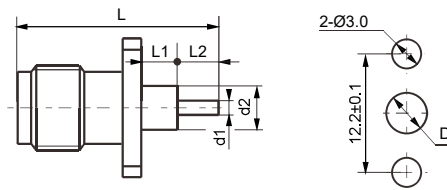

Type	L	L1	L2	d1	d2	D
SMA-KFD-69	15.6	2.0	4.0	Ø1.3	Ø4.1	Ø4.2
SMA-KFD-70	16.6	4.0	3.0	Ø1.3	Ø4.1	Ø4.2

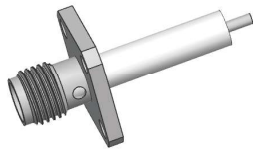

SMA-KFDG-7

PC BOARD LAYOUT

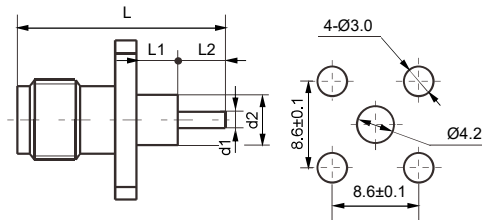

Type	L	L1	L2	d1	d2
SMA-KFDG-7	27.6	15.0	3.0	Ø1.3	Ø4.1
SMA-KFD-71	24.2	4.0	0.6	Ø0.4	Ø4.1
SMA-KFD-72	21.6	4.0	8.0	Ø1.3	Ø4.2

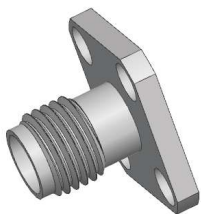

SMA-KFD-73

PC BOARD LAYOUT

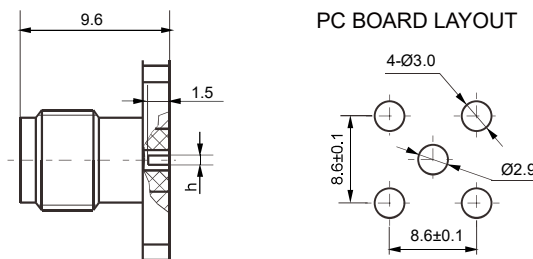

Type	h
SMA-KFD-73	0.2
SMA-KFD-74	0.4

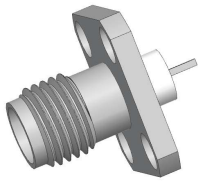

SMA-KFD-80

PC BOARD LAYOUT

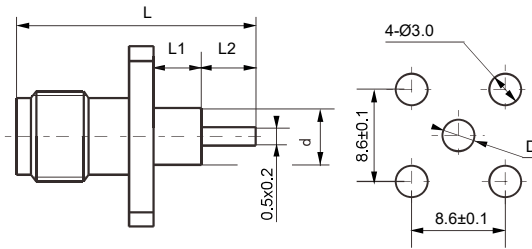

Type	L	L1	D	d
SMA-KFD-80	14.5	2.4	Ø4.2	Ø4.1
SMA-KFD-81	15.3	3.2	Ø2.2	Ø2.1
SMA-KFD-82	19.1	7.0	Ø4.2	Ø4.1

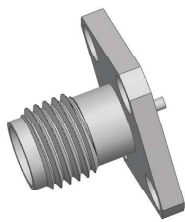

SMA-KFD-83

PC BOARD LAYOUT

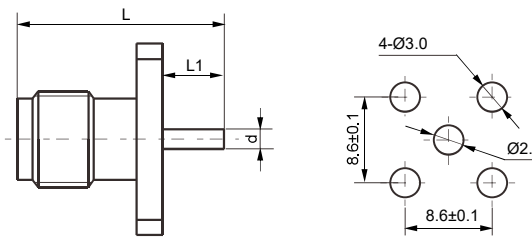

Type	L	L1	d
SMA-KFD-83	11.2	1.6	Ø0.9
SMA-KFD-84	10.8	1.2	Ø0.8
SMA-KFD-85	10.3	0.9	Ø0.6

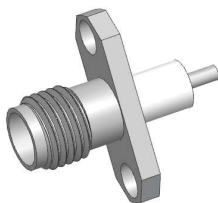

SMA-KFD-90

PC BOARD LAYOUT

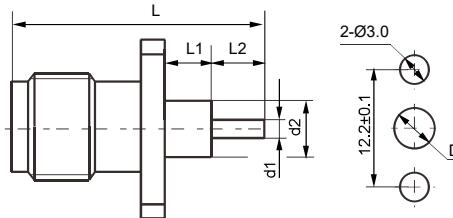

Type	L	L1	L2	d1	d2	D
SMA-KFD-90	17.6	5.0	3.0	Ø0.8	Ø4.1	Ø4.2
SMA-KFD-91	27.5	15.0	2.9	Ø1.3	Ø4.1	Ø4.2
SMA-KFD-92	15.6	2.0	4.0	Ø1.3	Ø4.1	Ø4.2

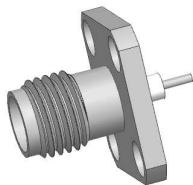

SMA-KFD-94

PC BOARD LAYOUT

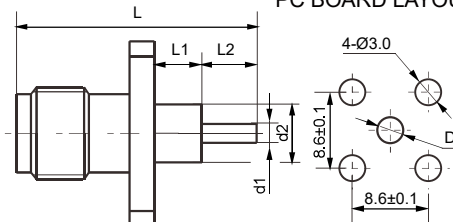

Type	L	L1	L2	d1	d2	D
SMA-KFD-94	15.3	3.2	2.5	Ø0.7	Ø2.1	Ø2.2
SMA-KFD-95	14.5	2.4	2.5	Ø1.3	Ø4.1	Ø4.2
SMA-KFD-96	27.6	13	5.0	Ø1.3	Ø4.1	Ø4.2

PC BOARD LAYOUT

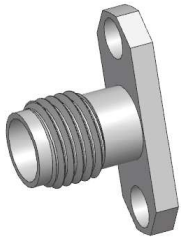

SMA-KFD-97

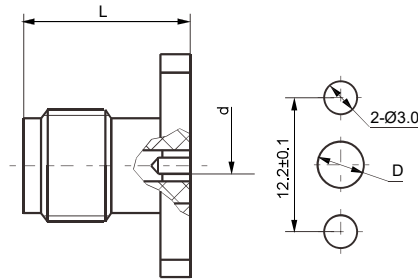

Type	h	d	D	Pin
SMA-KFD-97	12.2±0.1	Ø0.6	*	Ø0.47~Ø0.5
SMA-KFDG-98	12.2±0.1	Ø0.4	*	Ø0.35~Ø0.38
SMA-KFDG-99	12.2±0.1	Ø0.6	*	Ø0.47~Ø0.5

PC BOARD LAYOUT

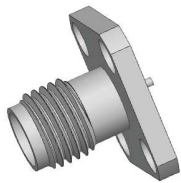

SMA-KFD-100

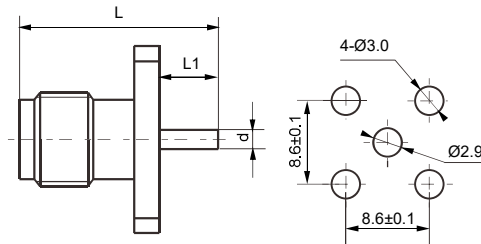

Type	L	L1	d
SMA-KFD-100	11.1	1.5	Ø0.7
SMA-KFD-101	14.1	1.5	Ø0.5

PC BOARD LAYOUT

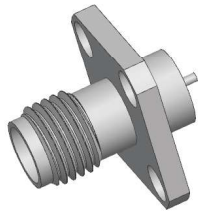

SMA-KFD-104

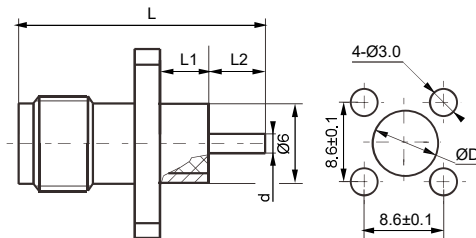

Type	L	L1	L2	d	D
SMA-KFD-104	14.1	3.0	1.5	Ø0.7	6.1
SMA-KFD-105	15.1	4.0	1.5	Ø0.8	6.1
SMA-KFDG-142	14.1	3.0	1.5	Ø0.7	6.2

PC BOARD LAYOUT

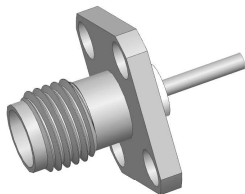

SMA-KFD-107

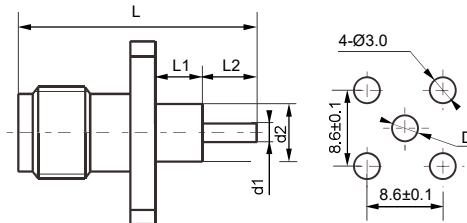

Type	L	L1	L2	d1	d2	D
SMA-KFD-107	24.3	1.6	13.1	Ø1.3	Ø4.1	Ø4.2
SMA-KFD-108	27.6	15	3.0	Ø1.3	Ø4.1	Ø4.2
SMA-KFD-109	19.1	7.5	2.0	Ø1.4	Ø4.1	Ø4.2

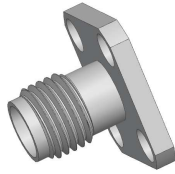

SMA-KFD-114

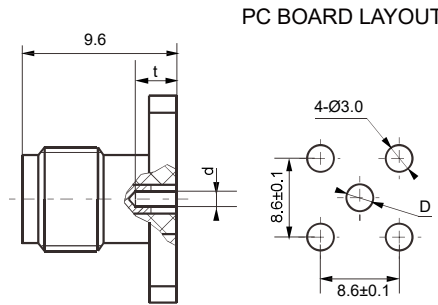

Type	t	d	D	Pin
SMA-KFD-114	2.8	Ø0.9	*	Ø0.9 ~ Ø0.93
SMA-KFD-115	2.8	Ø0.8	*	Ø0.78 ~ Ø0.8
SMA-KFD-116	2.6	Ø0.5	*	Ø0.45 ~ Ø0.48

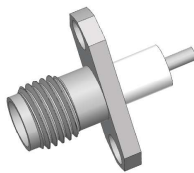

SMA-KFDG-118

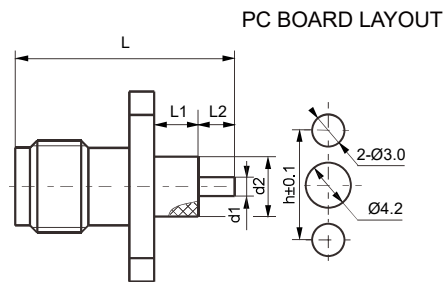

Type	L	L1	L2	d1	d2	h
SMA-KFDG-118	17.6	5.0	3.0	Ø1.8	Ø4.1	10.2
SMA-KFD-119	19.2	4.0	5.6	Ø0.7	Ø4.1	12.2
SMA-KFD-120	14.1	3.0	1.5	Ø1.3	Ø4.1	12.2

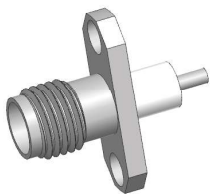

SMA-KFD-123

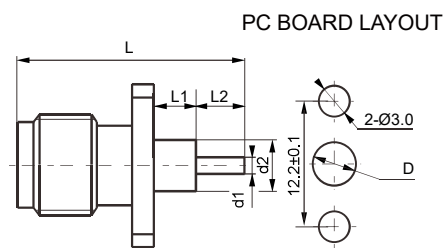

Type	L	L1	L2	d1	d2	D
SMA-KFD-123	17.0	3.0	3.0	Ø1.3	Ø4.1	Ø4.2
SMA-KFD-124	25.8	12.2	4.0	Ø1.3	Ø3.0	Ø3.1
SMA-KFD-125	14.8	3.2	2.0	Ø1.3	Ø4.1	Ø4.2
SMA-KFD-126	27.6	15.0	3.0	Ø1.3	Ø4.1	Ø4.2
SMA-KFD-127	34.6	20.0	5.0	Ø1.3	Ø4.1	Ø4.2
SMA-KFD-128	27.7	10.5	7.0	Ø0.8	Ø2.6	Ø2.7
SMA-KFD-129	14.1	2.0	2.5	Ø1.3	Ø4.1	Ø4.2
SMA-KFD-130	15.6	3.0	3.0	Ø1.0	Ø4.1	Ø4.2

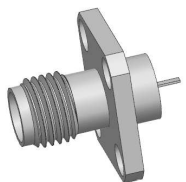

SMA-KFD-132

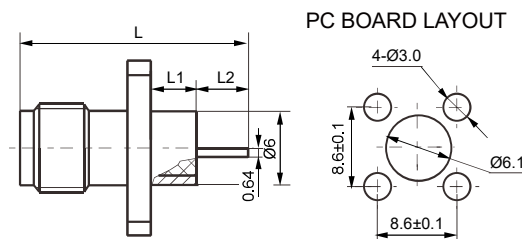

Type	L	L1	L2
SMA-KFD-132	15.1	3.0	2.5
SMA-KFD-133	15.6	4.0	2.0
SMA-KFD-134	17.1	5.0	2.5
SMA-KFD-135	16.1	4.0	2.5
SMA-KFD-136	17.6	5.0	3.0

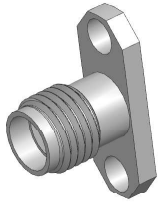

SMA-KFD-140

PC BOARD LAYOUT

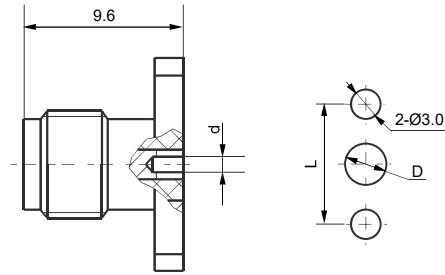

Type	L	d	D
SMA-KFD-140	12.2±0.1	Ø0.5	*
SMA-KFD-141	12.2±0.1	Ø0.5	*

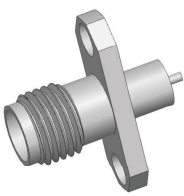

SMA-KFDG-148

PC BOARD LAYOUT

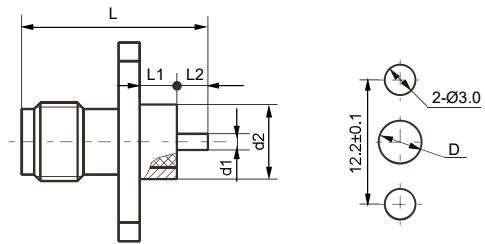

Type	L	L1	L2	d1	d2	D
SMA-KFDG-148	15.1	4.0	1.5	Ø0.8	Ø4.0	Ø4.1
SMA-KFD-149	14.6	2.5	2.5	Ø1.3	Ø6.0	Ø6.1
SMA-KFD-150	14.4	2.4	2.4	Ø0.5	Ø5.2	Ø5.3
SMA-KFD-151	14.0	2.4	2.0	Ø0.5	Ø5.2	Ø5.3
SMA-KFD-152	15.6	4.0	2.0	Ø0.8	Ø4.1	Ø4.2
SMA-KFD-153	15.6	4.0	2.0	Ø0.8	Ø4.1	Ø4.2
SMA-KFDG-154	16.9	4.0	3.3	Ø1.3	Ø6.0	Ø6.1

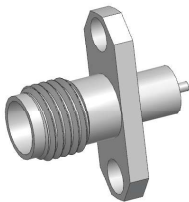

SMA-KFD-148

PC BOARD LAYOUT

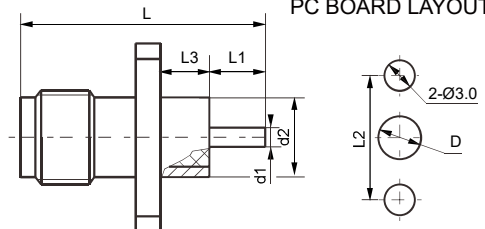

Type	L	L1	L2	L3	d1	d2	D
SMA-KFDG-148	15.1	1.5	12.2±0.1	4.0	Ø0.8	Ø4.1	Ø4.2
SMA-KFD-155	15.1	1.5	10.2±0.1	4.0	Ø0.8	Ø4.0	Ø4.1
SMA-KFD-156	14.4	0.8	12.2±0.1	4.0	Ø0.6	Ø4.0	Ø4.1
SMA-KFD-157	17.6	3.0	10.2±0.1	5.0	Ø1.0	Ø4.5	Ø4.6

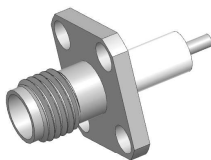

SMA-KFD-158

PC BOARD LAYOUT

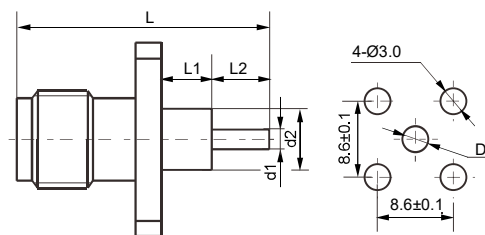

Type	L	L1	L2	d1	d2	D
SMA-KFDG-158	20.6	8.0	3.0	Ø1.3	Ø4.1	Ø4.2
SMA-KFD-159	18.8	3.0	4.2	Ø1.3	Ø4.1	Ø4.2
SMA-KFD-160	39.6	25.0	5.0	Ø1.3	Ø4.1	Ø4.2
SMA-KFD-161	17.6	25.0	12.0	Ø1.3	Ø4.1	Ø4.2

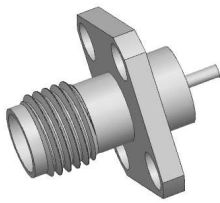

SMA-KFD-162

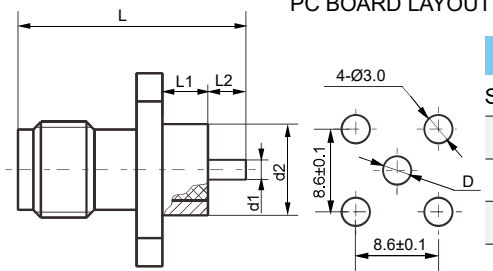

Type	L	L1	L2	d1	d2	D
SMA-KFDG162	15.6	3.0	3.0	Ø1.0	Ø6.0	Ø6.1
SMA-KFD163	18.6	4.0	5.0	Ø1.3	Ø6.0	Ø6.1
SMA-KFD164	15.6	2.4	2.0	Ø0.8	Ø4.8	Ø4.9
SMA-KFD165	14.4	4.0	2.4	Ø0.5	Ø5.2	Ø5.3
SMA-KFD166	14.4	4.0	0.8	Ø0.6	Ø4.0	Ø4.1

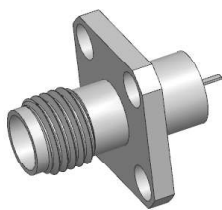

SMA-KFD-167

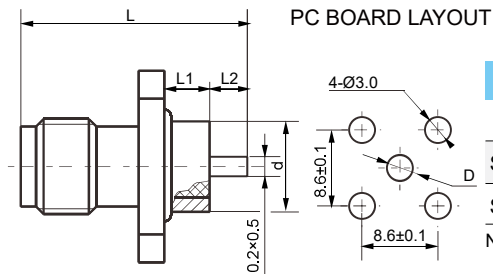

Type	L	L1	L2	d	D
SMA-KFD-167	17.1	5.0	2.5	Ø6.0	Ø6.1
SMA-KFDG-167	17.1	5.0	2.5	Ø6.0	Ø6.1
SMA-KFDG-168	21.2	5.0	6.6	Ø6.0	Ø6.1

Notes: The microstrip size of SMA-KFD206G Ø 1.3

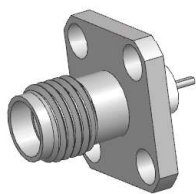

SMA-KFD-169

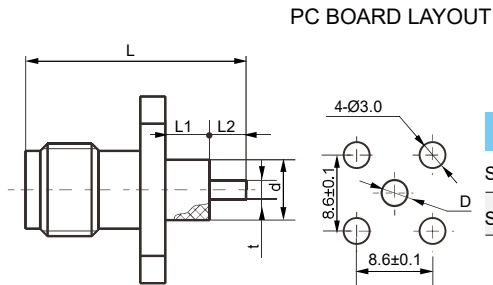

Type	L	L1	L2	t	d	D
SMA-KFD-169	15.3	3.2	2.5	Ø0.7×0.5 Semicircle	Ø2.1	Ø2.2
SMA-KFD-170	13.3	1.5	2.2	Ø1.3×0.65 Semicircle	Ø4.1	Ø4.2

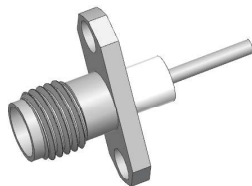

SMA-KFD-172

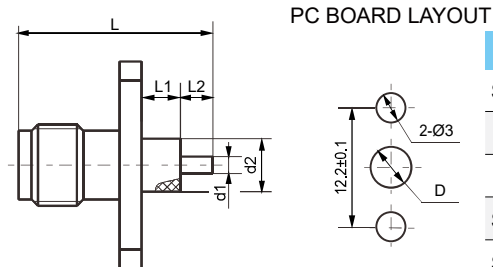

Type	L	L1	L2	d1	d2	D
SMA-KFD-172	17.6	6.0	2.0	Ø1.3	Ø4.1	Ø4.2
SMA-KFD-10	21.6	4.0	8.0	Ø1.3	Ø4.1	Ø4.2
SMA-KFD-14	15.6	4.0	2.0	Ø1.3	Ø4.1	Ø4.2
SMA-KFD-173	81.1	62.0	9.5	Ø1.3	Ø4.1	Ø4.2
SMA-KFD-174	20.6	7.0	4.0	Ø1.3	Ø3.0	Ø3.1
SMA-KFD-175	40.8	20.6	10.0	Ø1.0	Ø4.1	Ø4.2

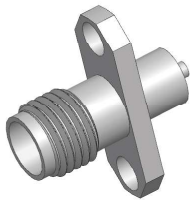

SMA-KFD-176

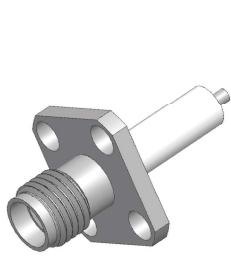
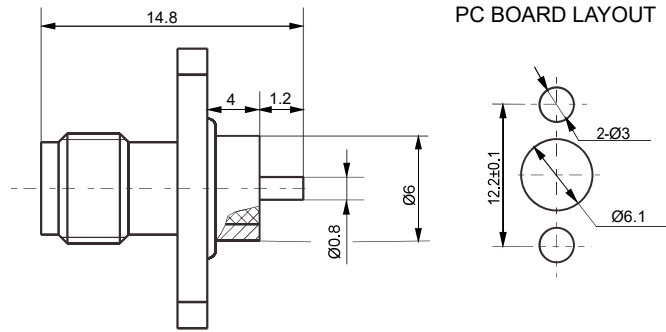

SMA-KFD-178

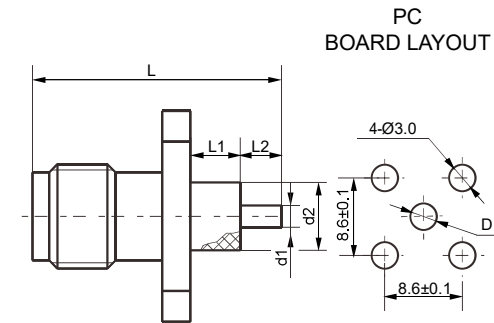

Type	L	L1	L2	d1	d2	D
SMA-KFD-178	23.6	12	2.0	Ø1.3	Ø4.1	Ø4.2
SMA-KFD-179	24.1	9.0	5.5	Ø1.3	Ø4.1	Ø4.2
SMA-KFD-180	16.6	5.0	2.0	Ø1.3	Ø4.1	Ø4.2
SMA-KFD-181	17.0	5.4	2.0	Ø1.3	Ø4.1	Ø4.2
SMA-KFD-182	27.6	4.0	14.0	Ø1.3	Ø4.1	Ø4.2
SMA-KFD-183	33.6	4.0	20.0	Ø1.3	Ø4.1	Ø4.2

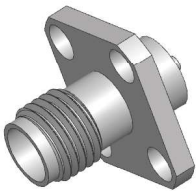

SMA-KFD-184

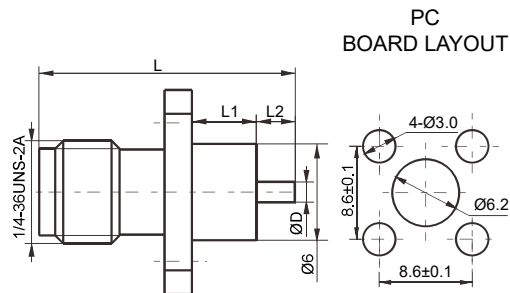

Type	L	L1	L2	D
SMA-KFD-184	14.0	3.2	1.2	1.3
SMA-KFDG-184	14.0	3.2	1.2	1.3
SMA-KFDG-185	15.1	4.0	1.5	0.8

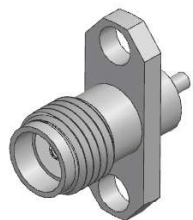

SMA-KFD-186

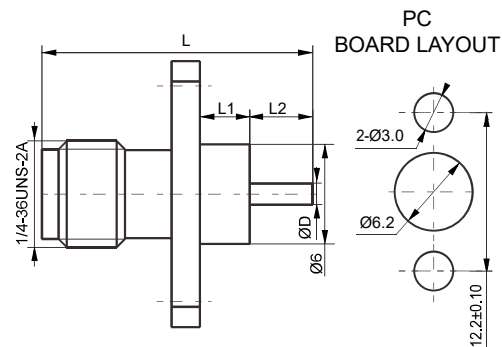

Type	L	L1	L2	D
SMA-KFD-186	15.0	2.4	3.0	1.3
SMA-KFD-187	15.8	3.2	3.0	1.3
SMA-KFD-188	17.4	4.8	3.0	1.3

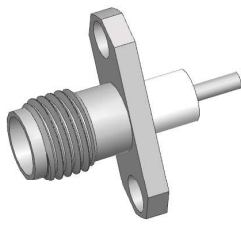

SMA-KFD-189

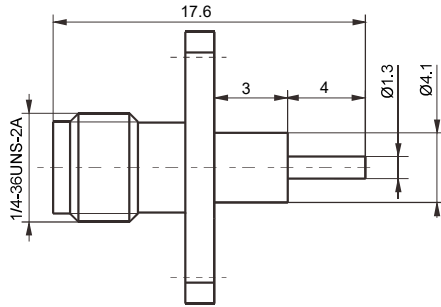

PC BOARD LAYOUT

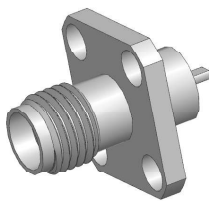
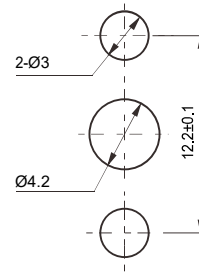

SMA-KFD-190

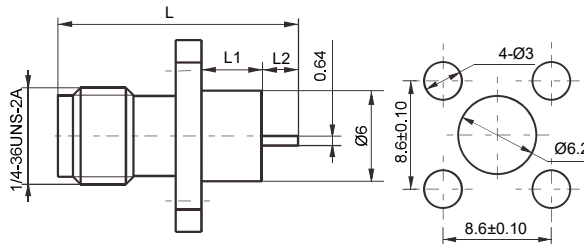

PC BOARD LAYOUT

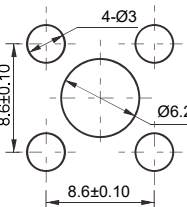

Type	L	L1	L2
SMA-KFD-190	16.0	4.0	2.4
SMA-KFD-191	15.6	4.0	2.0

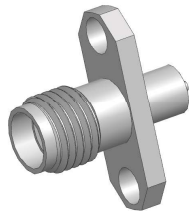

SMA-KFD-197

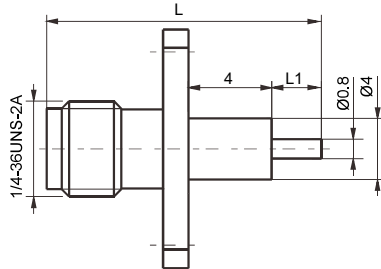

PC BOARD LAYOUT

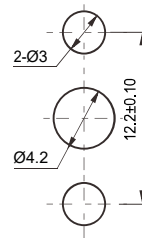

Type	L	L1
SMA-KFD-197	14.6	1.0
SMA-KFD-198	16.1	2.5

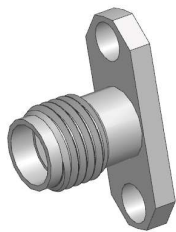

SMA-KFD-203

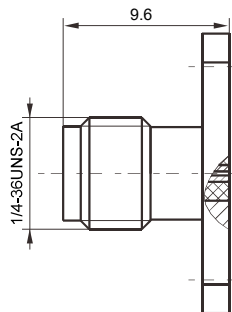

PC BOARD LAYOUT

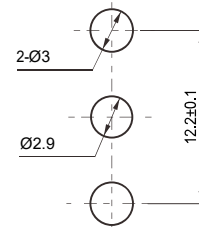

Note: The groove is parallel to the long side of the flange, with a groove width of 0.2mm

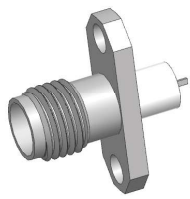

SMA-KFD-206

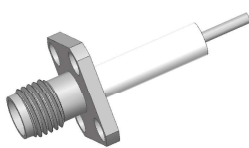
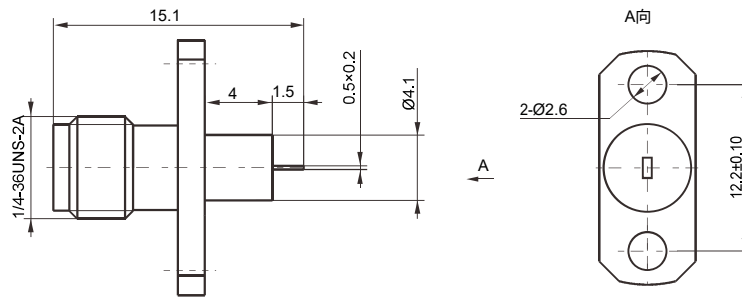

SMA-KFD-211

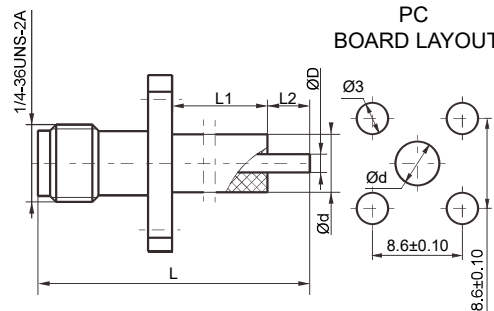

PC BOARD LAYOUT

Type	L	L1	L2	D	d
SMA-KFD-211	30.2	14.4	6.2	1.3	4.1
SMA-KFD-212	55.6	34.0	12.0	1.3	4.1
SMA-KFD-213	27.6	0	18.0	1.3	2.9
SMA-KFD-214	15.8	3.0	3.0	1.0	4.1
SMA-KFD-215	19.6	9.0	1.0	1.1	3.8
SMA-KFD-216	30.0	6.5	5.5	1.3	4.1
SMA-KFD-217	24.6	12.0	3.0	1.3	4.1
SMA-KFD-218	16.2	3.8	2.8	0.8	4.1

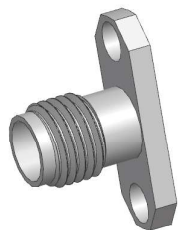

SMA-KFDG-221

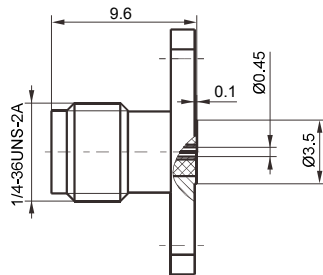

PC BOARD LAYOUT

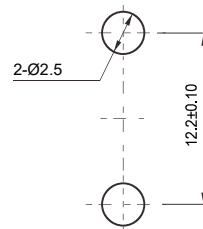

Note: The tail is equipped with a 0.35-0.38mm pin

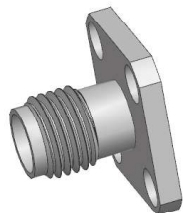

SMA-KFDG-222

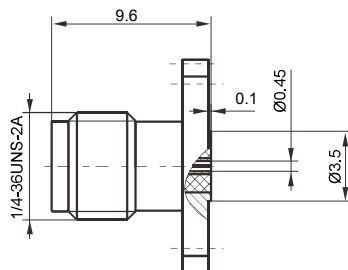

PC BOARD LAYOUT

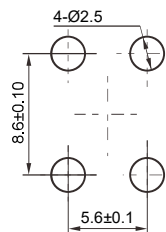

Note: The tail is equipped with a 0.35-0.38mm pin

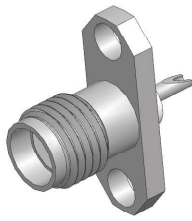

SMA-KFDG-228

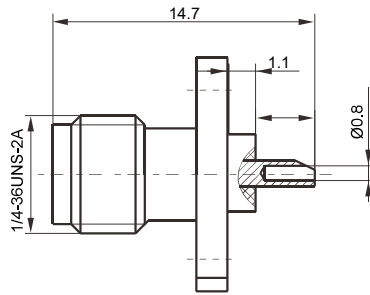

PC BOARD LAYOUT

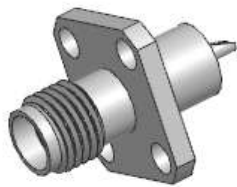
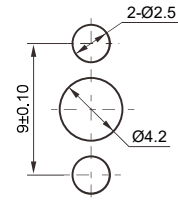

SMA-KFD-230

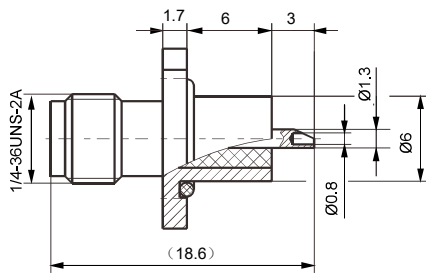

FLANGE SIZE

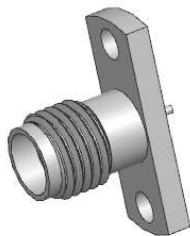
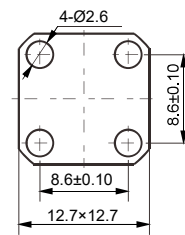

SMA-KFD-234

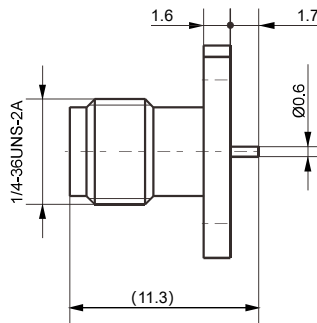

FLANGE SIZE

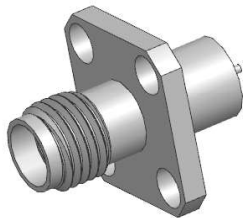
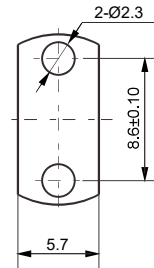

SMA-M-KFD-236

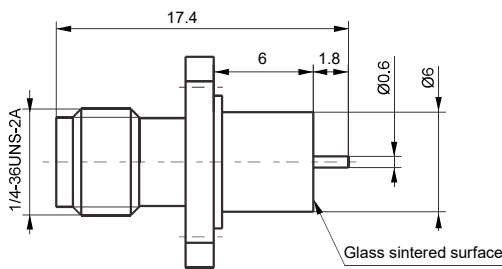

PC BOARD LAYOUT

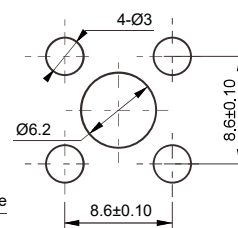

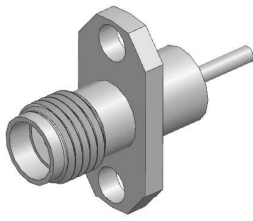

SMA-M-KFD-238

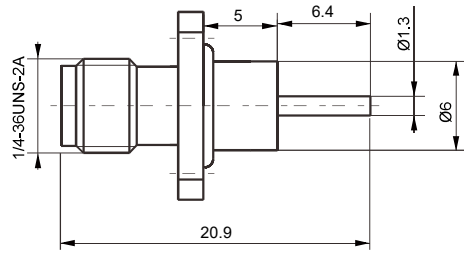

PC BOARD LAYOUT

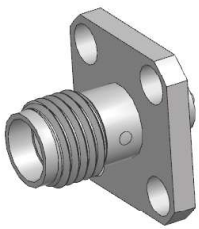
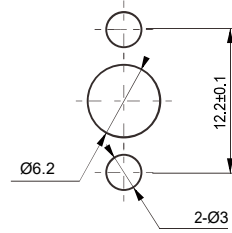

SMA-KFD-242

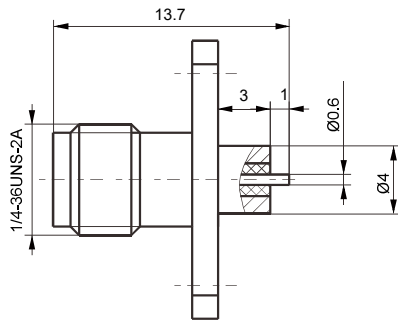

PC BOARD LAYOUT

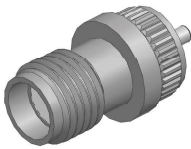
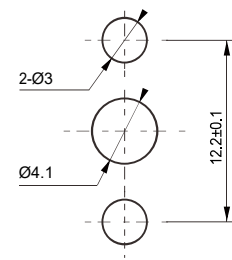

SMA-KPD

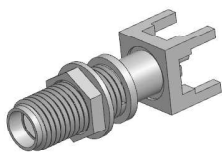
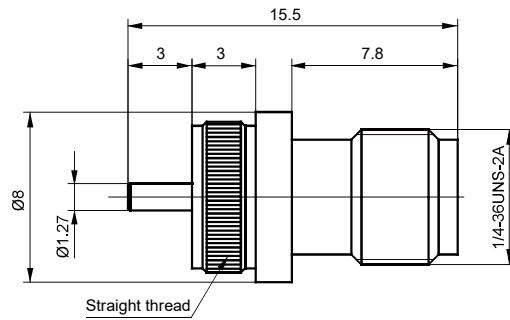

SMA-KYHE

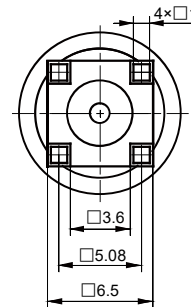
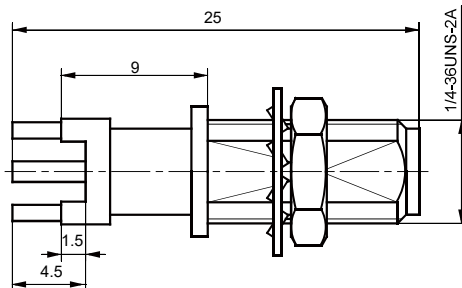

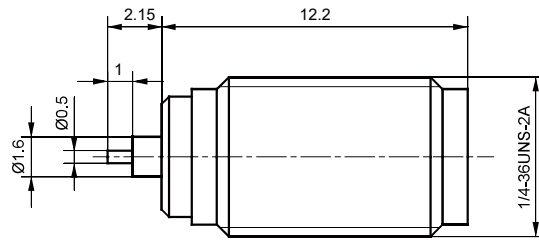

SMA-KDG

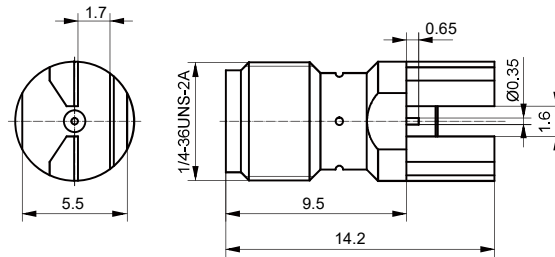
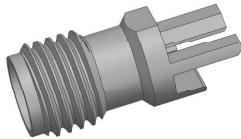

SMA-KHE-10

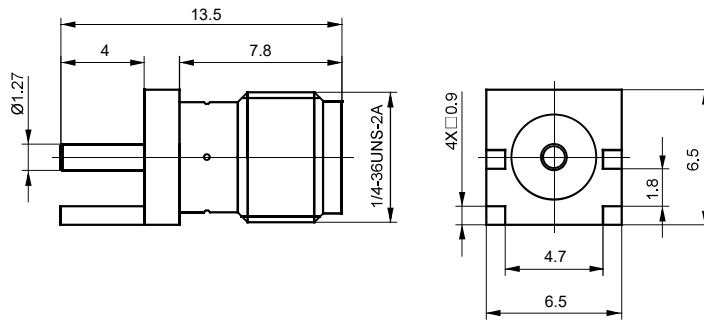
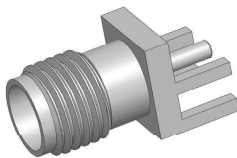

SMA-KHE-6

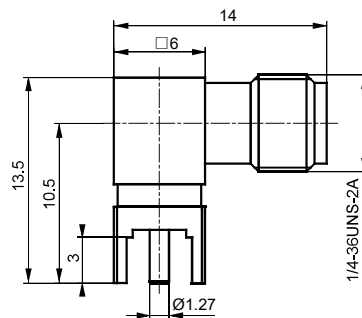
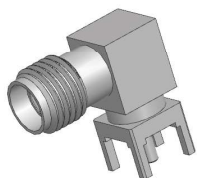

SMA-KWHE

PC BOARD LAYOUT

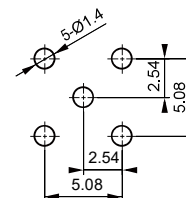

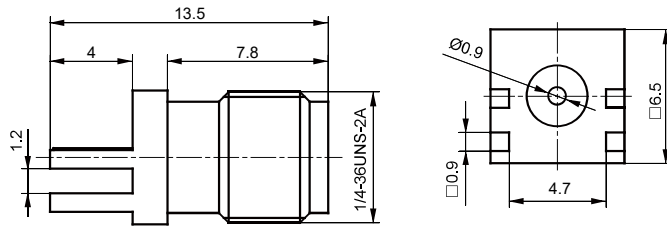
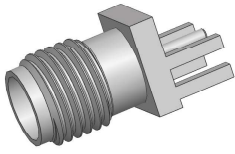

SMA-KHE-2

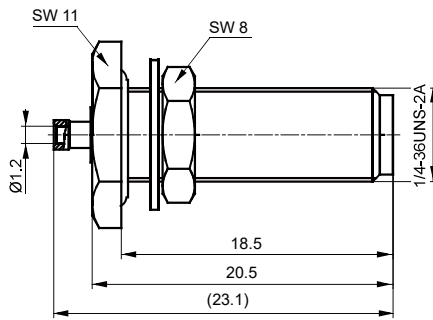
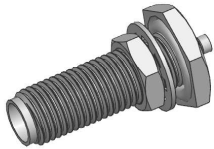

PC BOARD LAYOUT

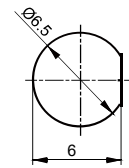

SMA-KY1.13

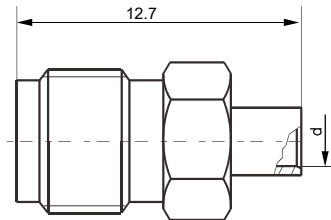
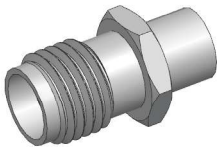

Cable stripping size

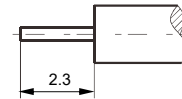

Type	d	Cable
SMA-KB2	Ø2.2	SFT-50-2-1
SMA-KB3	Ø3.6	SFT-50-3-1

SMA-KB2

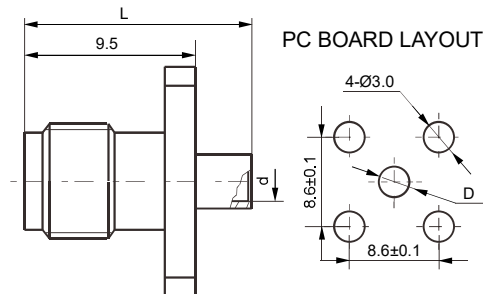
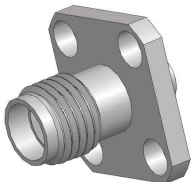

PC BOARD LAYOUT

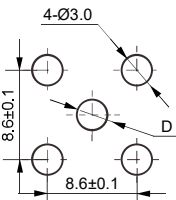

Cable stripping size

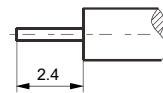

Type	d	D	L	Cable
SMA-KFB1	Ø1.2	Ø3.2	12.7	SFT-50-1
SMA-KFB2	Ø2.2	Ø3.5	12.7	SFT-50-2-1
SMA-KFB3	Ø3.6	Ø5.0	14.2	SFT-50-3-1

SMA-KFB1

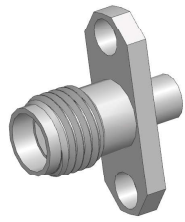

SMA-KFB2-1

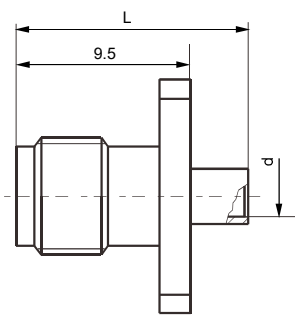

PC BOARD LAYOUT

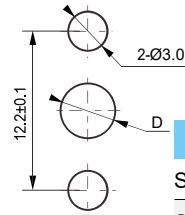

CABLE STRIPPING SIZE

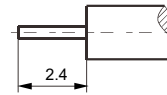

Type	d	D	L	Cable
SMA-KFB2-1	Ø2.2	Ø3.5	12.7	SFT-50-2-1
SMA-KFB3-1	Ø3.6	Ø5.0	14.2	SFT-50-3-1

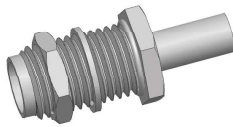

SMA-KYB2-1

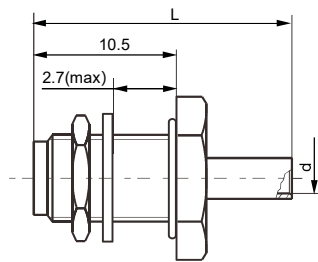

PC BOARD LAYOUT

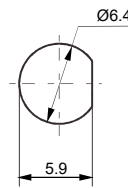

CABLE STRIPPING SIZE

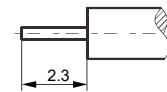

Type	d	L1	Cable
SMA-KYB2-1	Ø2.2	19.0	SFT-50-2-1
SMA-KYB3	Ø3.6	19.0	SFT-50-3-1
SMA-KYB3-1	Ø3.6	15.9	SFT-50-3-1

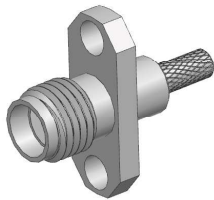

SMA-KF3Y-1

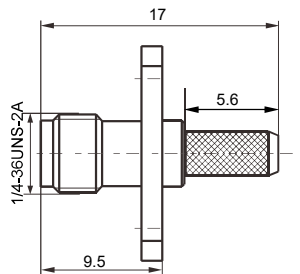

PC BOARD LAYOUT

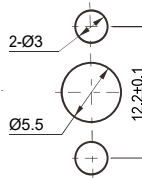

CLAMP

CABLE STRIPPING SIZE

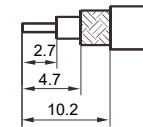
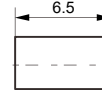

Type	Cable
SMA-KF3Y-1	SYV-50-2-1, SFF-50-1.5-1

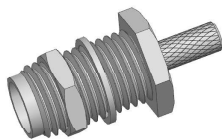

SMA-KY3Y-1

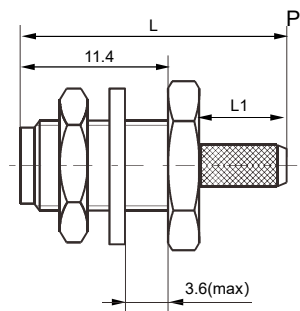

PC BOARD LAYOUT

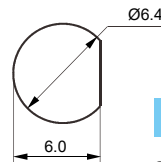

CLAMP

CABLE STRIPPING SIZE

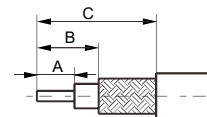
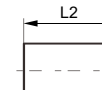

Type	L	L1	L2	A	B	C	Cable
SMA-KY3Y-1	18.8	5.6	6.5	2.5	6.7	12.3	SFF-50-1.5-1 SYV-50-2-1
SMA-KY4Y	21.2	8.0	10.0	2.5	5.4	13.4	SFF-50-2-2 SYV-50-2-2
SMA-KY5Y	23.2	10.0	12.0	2.5	5.4	15.4	SFF-50-3-1 SYV-50-3

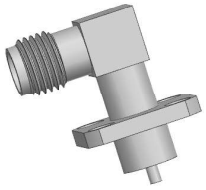

SMA-KWFD-10

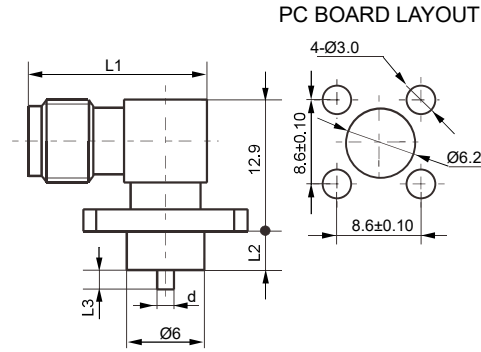

Type	L1	L2	L3	d
SMA-KWFD-10	14.8	4.0	2.0	Ø1.3
SMA-KWFD-11	14.8	2.4	5.0	Ø1.3
SMA-KWFD-12	23.3	4.0	2.0	Ø1.3



SMA-KWFD-14

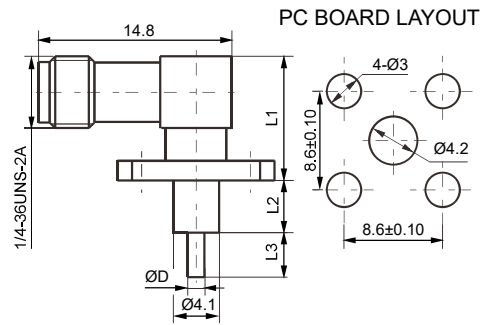

Type	L1	L2	L3	D
SMA-KWFD-14	11.4	8.8	0.2	Ø1.3
SMA-KWFD-15	11.4	4.0	3.5	Ø1.3
SMA-KWFD-16	10.9	4.0	5.0	Ø1.3
SMA-KWFD-17	12.9	5.0	3.0	Ø1.3
SMA-KWFD-18	12.9	7.0	4.5	Ø1.3
SMA-KWFD-19	12.9	0	7.8	Ø1.3
SMA-KWFD-20	12.9	11.5	2.0	Ø0.8

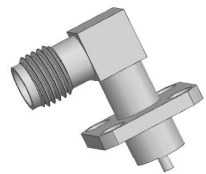

SMA-KWFD-21

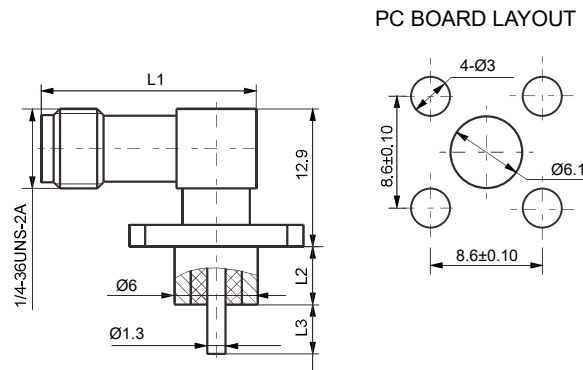

Type	L1	L2	L3
SMA-KWFD21	23.3	4	2
SMA-KWFD38	14.9	4	2
SMA-KWFD40	14.9	3	6

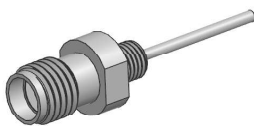

SMA-KYD-1

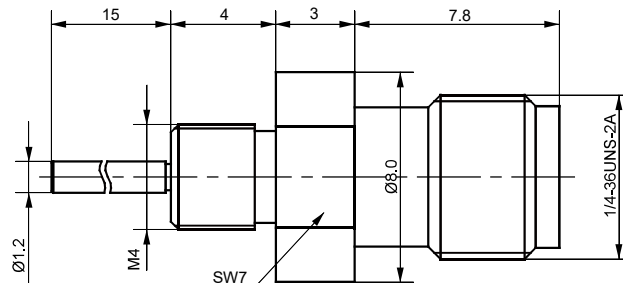

SMA-KYD-11

PC BOARD LAYOUT

Type	L	L1	D	d	D1
SMA-KYD-11	16.6	2.8	1/4-36UNS-2A	0.6	6.4
SMA-KYD-12	19.1	3.0	M7×0.75	0.7	7.1

SMA-KYD-14

PC BOARD LAYOUT

SMA-KHD-2

PC BOARD LAYOUT

Type	L	L1	D	d	Notes
SMA-KHD-2	13.5	4.0	0.8	0.9	
SMA-KHD-3	20.7	4.0	1.3	1.4	
SMA-KHD-4	14.5	5.0	1.3	1.4	Shell nickel plating
SMA-KHD-5	15.5	3.0	1.3	1.4	

SMA-KHD-6

PC BOARD LAYOUT

Type	A
SMA-KHD-6	2.0
SMA-KHD-7	1.8
SMA-KHD-8	2.2
SMA-KHD-9	1.1

PC BOARD LAYOUT

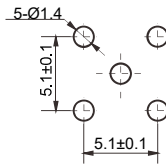
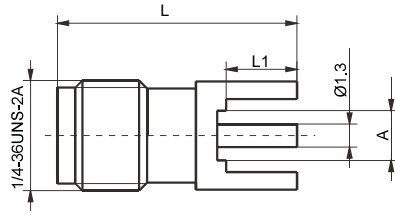
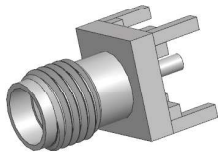

Type	L	L1	A
SMA-KHD-10	13.5	4.0	3.5
SMA-KHD-11	13.5	4.0	2.8
SMA-KHD-12	15.8	6.3	2.8

SMA-KHD-10

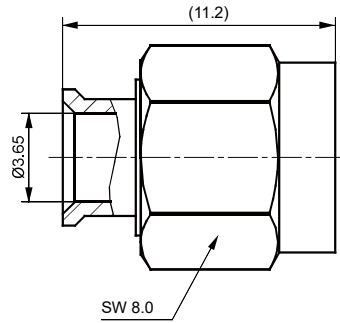
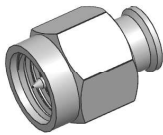

SMA-JB3

CABLE STRIPPING SIZE

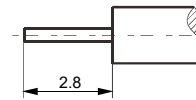
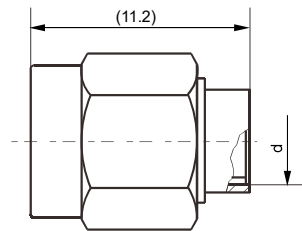
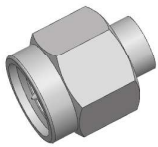

Type	d	Cable	Notes
SMA-JBG2	Ø2.2	SFT-50-2-1	Stainless steel screw sleeve
SMA-JB3G-4	Ø3.6	SFT-50-3-1	passivation,copper shell gold plating

SMA-JB2G

CABLE STRIPPING SIZE

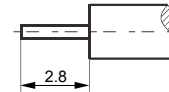
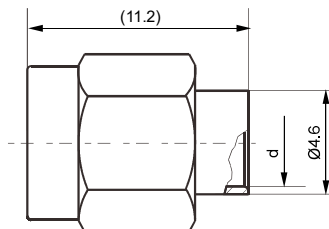
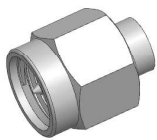

Type	d	Cable	Notes
SMA-JB2-4	Ø2.2	SFT-50-2-1	Retractable screw sleeve
SMA-JB3-5	Ø3.6	SFT-50-3-1	Retractable screw sleeve

SMA-JB2-4



SMA-JB2-5

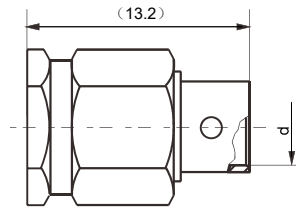

CABLE STRIPPING SIZE

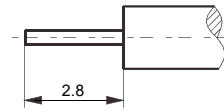

Type	D	Cable
SMA-JB2-5	Ø2.2	SFT-50-2-1
SMA-JB3-6	Ø3.6	STF-50-3-1

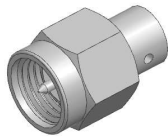

SMA-JB3-8

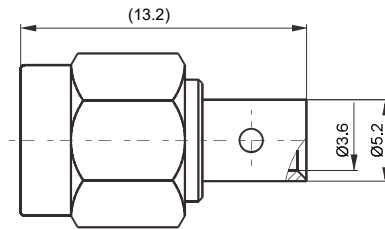

CABLE STRIPPING SIZE

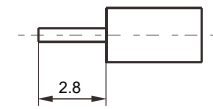

Type	Cable
SMA-JB3-8	SFT-50-3-1

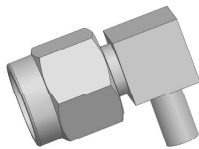

SMA-JWB2

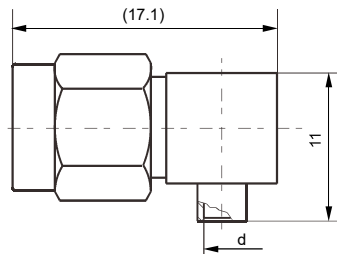

CABLE STRIPPING SIZE

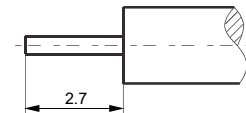

Type	D	Cable
SMA-JWB2	Ø2.2	SFT-50-2-1
SMA-JWB3	Ø3.6	STF-50-3-1

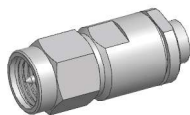

SMA-J402G

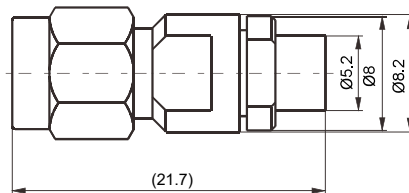

CABLE STRIPPING SIZE

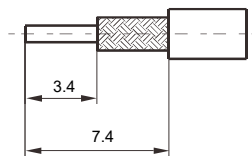

Type	Cable
SMA-J402G	TFLEX402

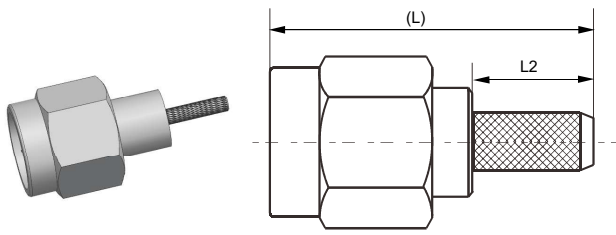

SMA-J4Y

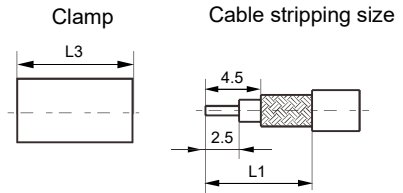

Type	L	L1	L2	L3	Cable
SMA-J4Y	21.5	12.5	8.0	10.0	SFF-50-2-2
					SYV-50-2-2
SMA-J5Y	23.7	14.5	10.0	12.0	SFF-50-3
					SYV-50-3-1

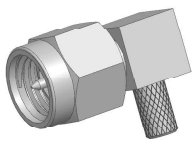

SMA-JW2Y

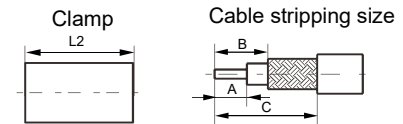

Type	L	L1	L2	A	B	C	Cable
SMA-JW2Y	13.0	5.7	6.5	2.7	4.6	102	SFF-50-1
							SYV-50-1
SMA-JW3Y-1	13.0	5.7	6.5	2.7	4.6	102	SFF-50-1.5-1
							SYV-50-2-1
SMA-JW4Y	16.0	8.0	10.0	3.0	5.0	130	SFF-50-2-2
							SYV-50-2-2
SMA-JW5Y	18.0	10.0	12.0	3.0	5.0	150	SFF-50-3-1
							SYV-50-3



SMA-JW5AY

Type	Cable	Notes
SMA-J480BG	CXN3449 or equivalent cable	stainless steel



SMA-J480BG

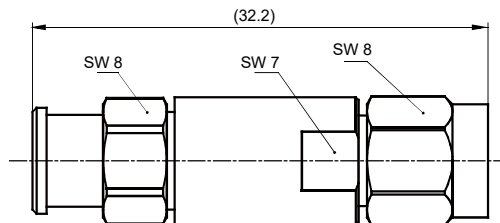

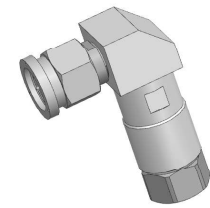

SMA-JW480BG

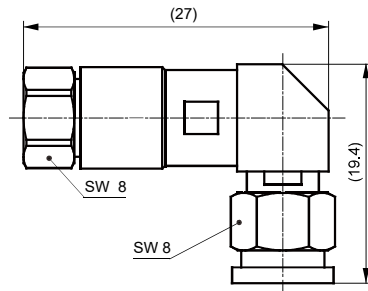

Type	Cable	Notes
SMA-JW480BG	CNX3449 or equivalent cable	stainless steel

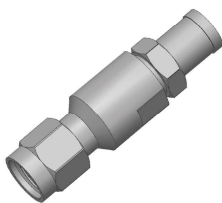

SMA-J141G

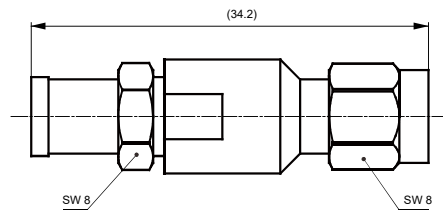

Type	Cable	Notes
SMA-J141G	CLL50141 or equivalent cable	stainless steel

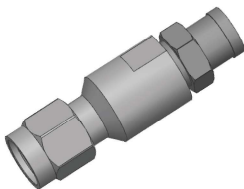

SMA-J5AG

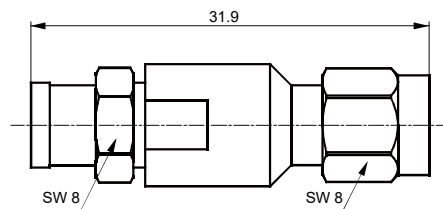

Type	Cable	Notes
SMA-J5AG	RG142/U or equivalent cable	stainless steel

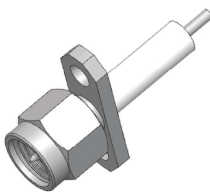

SMA-JFD-10

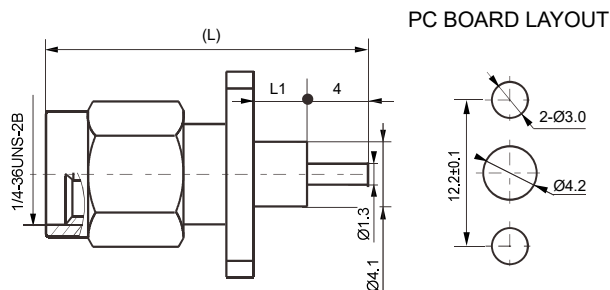

Type	L	L1
SMA-JFD10	25.4	8.6
SMA-JFD11	18.7	2.0

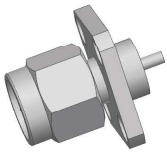

SMA-JFD-12

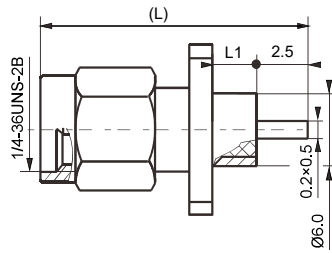

PC BOARD LAYOUT

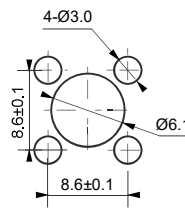

Type	L	L1
SMA-JFD-12	17.8	2.4
SMA-JFD-13	18.6	3.2
SMA-JFD-14	20.2	4.8
SMA-JFD-15	19.7	4.0

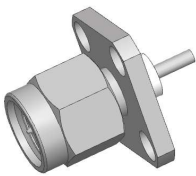

SMA-JFD-16

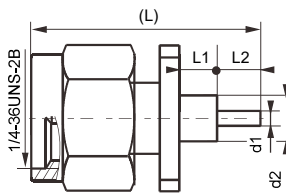

PC BOARD LAYOUT

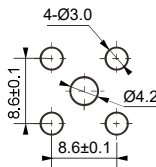

Type	L	L1	L2	d1	d2
SMA-JFD-16	18.7	2.0	4.0	Ø1.3	Ø4.1
SMA-JFD-17	23.1	8.4	2.0	Ø1.3	Ø4.1
SMA-JFD-18	25.1	8.4	4.0	Ø1.3	Ø4.1
SMA-JFD-19	17.3	4.0	0.6	Ø1.4	Ø4.1
SMA-JFD-20	24.9	4.0	8.0	Ø1.3	Ø4.1
SMA-JFD-21	23.9	3.0	8.0	Ø1.3	Ø4.1

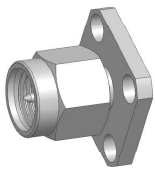

SMA-JFD-22

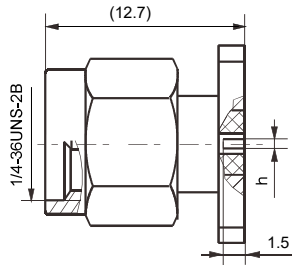

PC BOARD LAYOUT

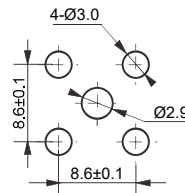

Type	h
SMA-JFD-22	0.2
SMA-JFD-23	0.4

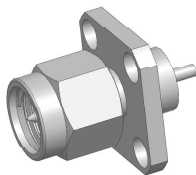

SMA-JFD-24

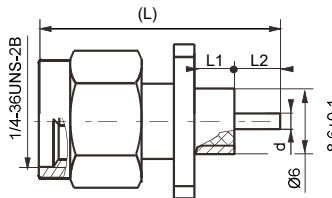

PC BOARD LAYOUT

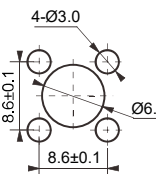

Type	L	L1	L2	d
SMA-JFD-24	18.9	3.2	3.0	Ø1.3
SMA-JFD-25	19.2	4.0	2.5	Ø1.3

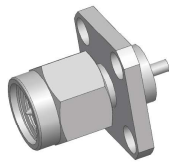

SMA-JFD-27

PC BOARD LAYOUT

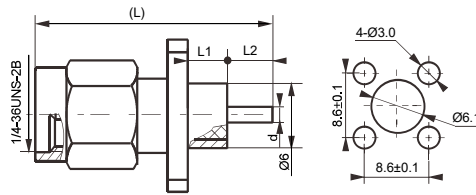

Type	L	L1	L2	d
SMA-JFD-27	17.6	2.4	2.5	Ø1.0
SMA-JFD-28	17.2	3.0	1.5	Ø0.7
SMA-JFD-29	18.4	1.0	4.5	Ø1.3

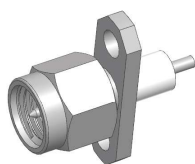

SMA-JFD-30

PC BOARD LAYOUT

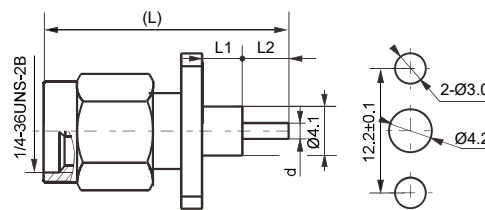

Type	L	L1	L2	d
SMA-JFD-30	20.7	5.0	3.0	Ø0.8
SMA-JFD-31	20.7	6.0	2.0	Ø1.3
SMA-JFD-32	24.7	4.0	8.0	Ø1.3
SMA-JFD-33	20.5	5.0	2.7	Ø1.3

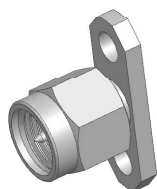

SMA-JFD-34

PC BOARD LAYOUT

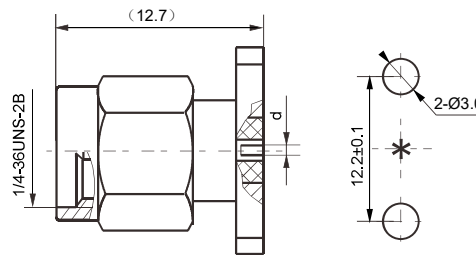

Type	d	Pin
SMA-JFD-34	Ø0.4	—
SMA-JFD-35	Ø0.9	Ø0.9~Ø0.93
SMA-JFD-36	Ø0.9	Ø0.9~Ø0.93
SMA-JFD-37	Ø0.8	Ø0.8~Ø0.83
SMA-JFD-38	Ø0.5	Ø0.48~Ø0.52

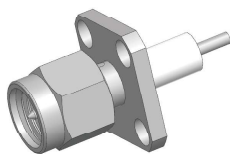

SMA-JFDG-18

PC BOARD LAYOUT

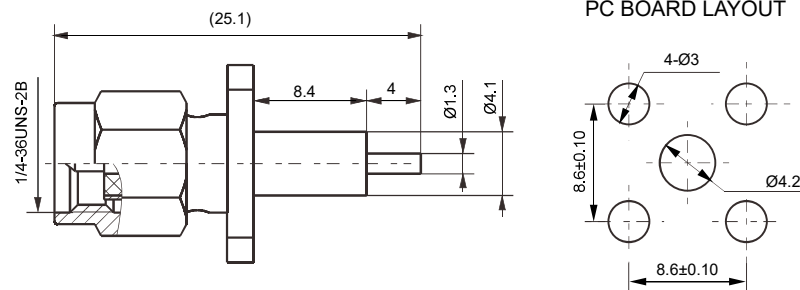

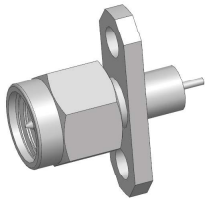

SMA-JFDG-41

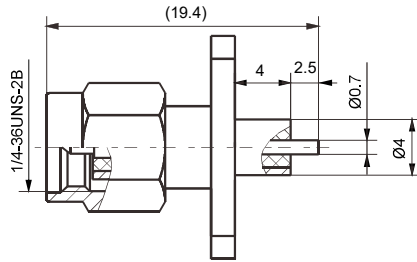

PC BOARD LAYOUT

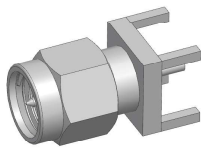
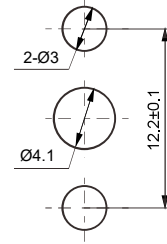

SMA-JHD

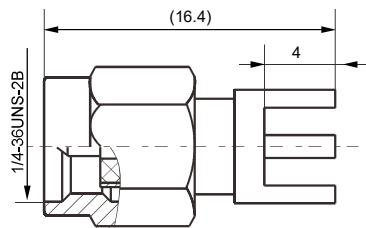

PC BOARD LAYOUT

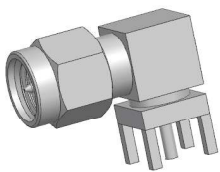
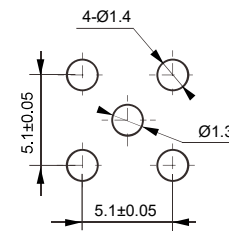

SMA-JWHD

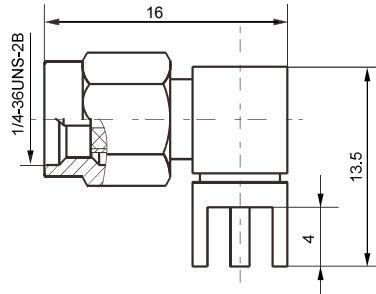

PC BOARD LAYOUT

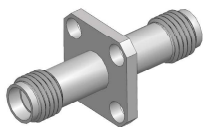
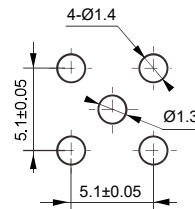

SMA-KFK

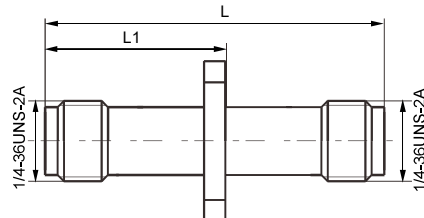

PC BOARD LAYOUT

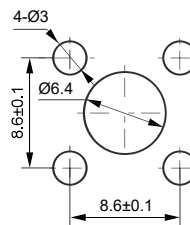

Type	L	L1
SMA-KFK	27.0	14.35
SMA-KFK-1	30.0	20.2
SMA-KFK-2	23.0	10.0
SMA-KFK-3	23.0	14.3

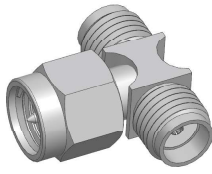

SMA-KJK

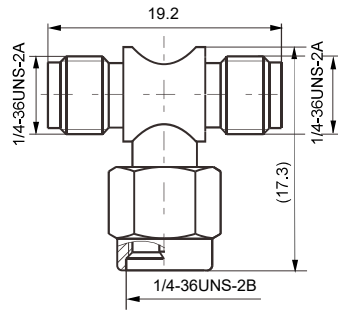

SMA-KKK

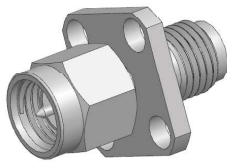
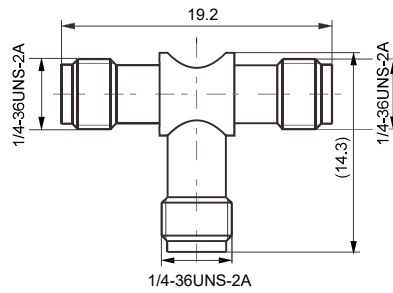

SMA-KFJ

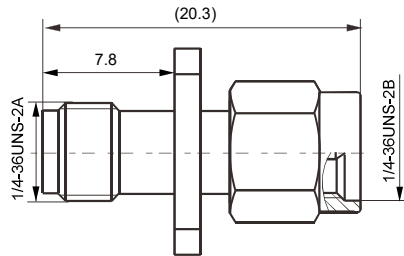

PC BOARD LAYOUT

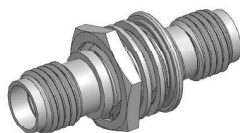
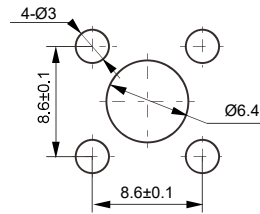

SMA-KYK-1

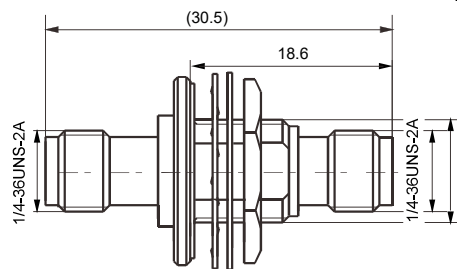

PC BOARD LAYOUT

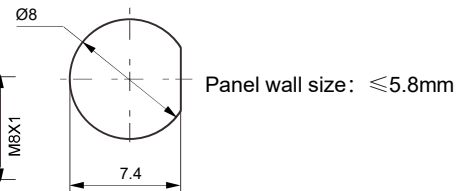

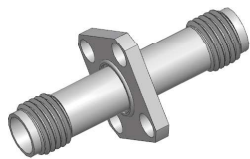

SMA-KFK-4

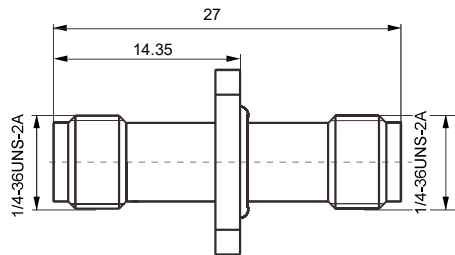

PC BOARD LAYOUT

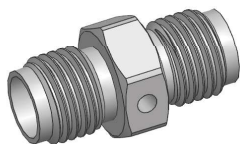
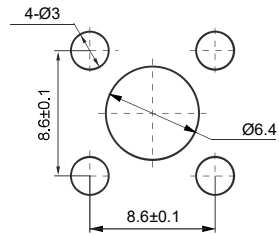

SMA-KK

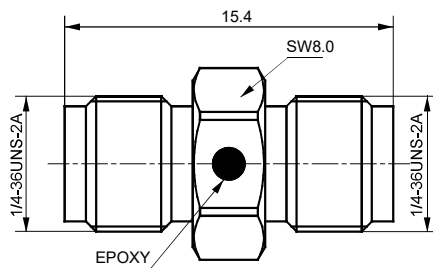

PC BOARD LAYOUT

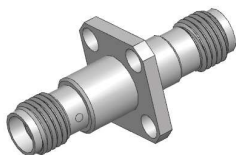
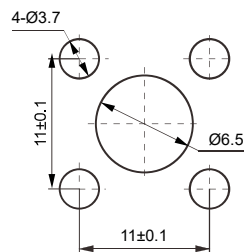

SMA-M-KFK-5

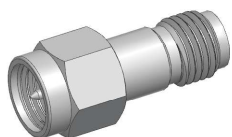
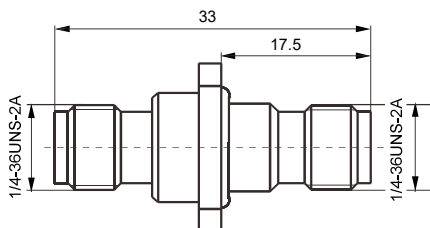

SMA-JK

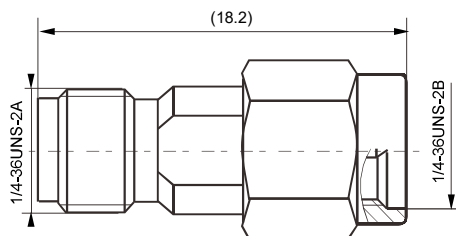

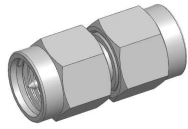

SMA-JJ

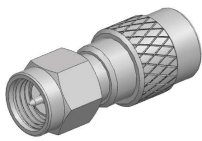
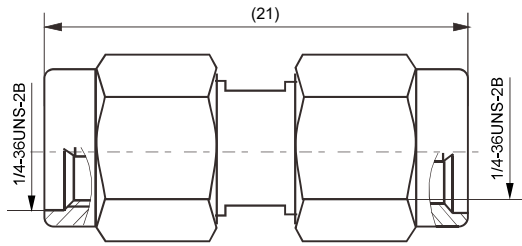

(SO)/SMA-JJG

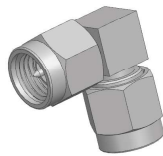
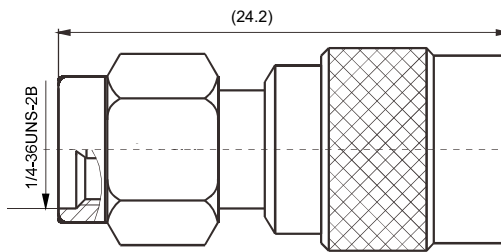

SMA-JWJ

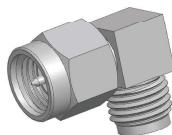
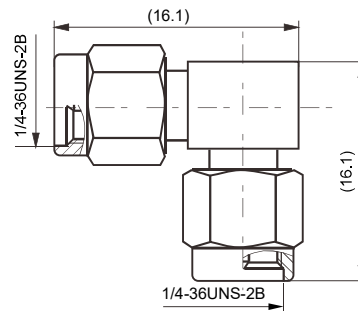

SMA-JWK

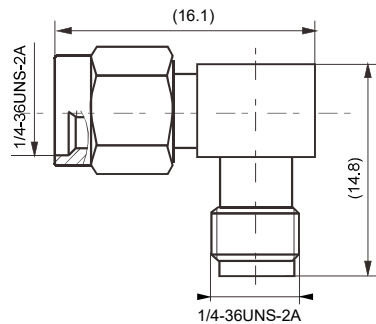

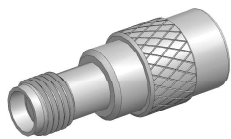

(SO)/SMA-KJ

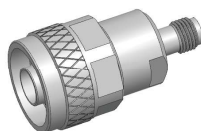
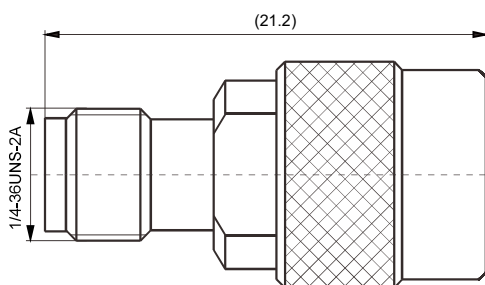

N/SMA-JK

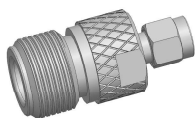
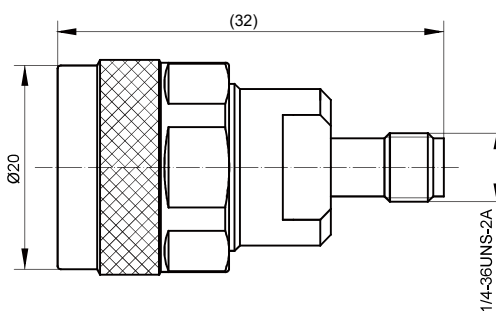

N/SMA-KJ

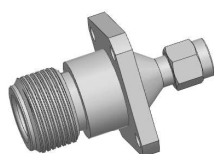
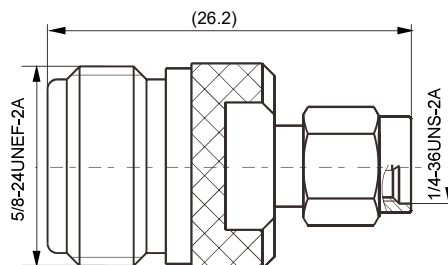

N/SMA-KFJ

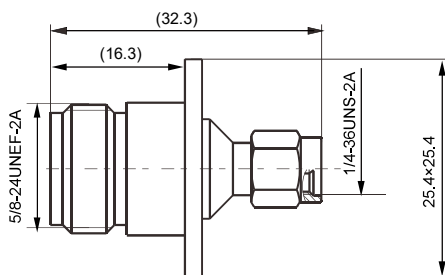

PC BOARD LAYOUT

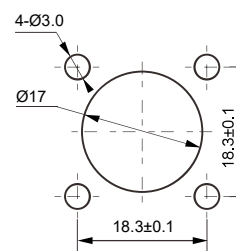

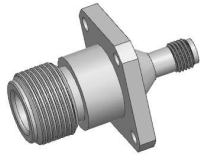

N/SMA-KFK

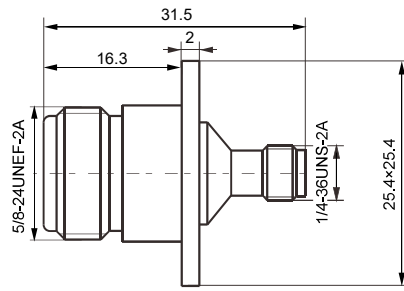

PC BOARD LAYOUT

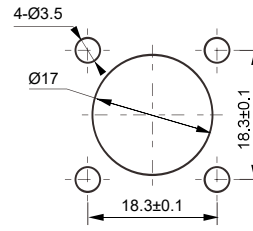

BNC/SMA-JK

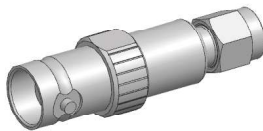
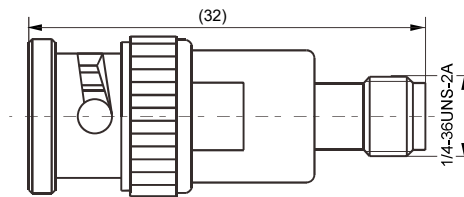

BNC/SMA-KJ

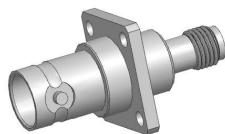
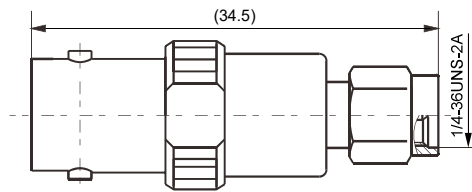

BNC/SMA-KFK

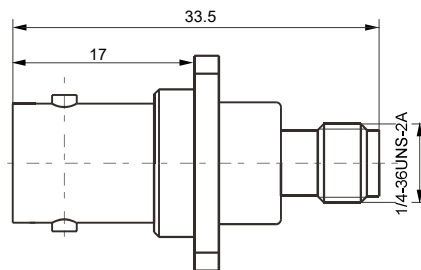

PC BOARD LAYOUT

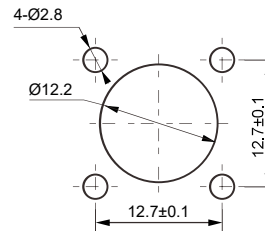

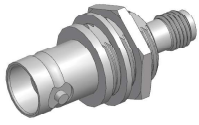

BNC/SMA-KYK

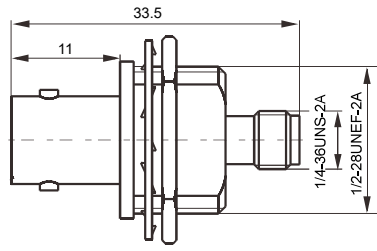

PC BOARD LAYOUT

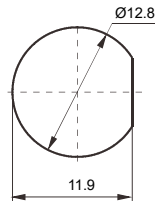

Panel wall size: $\leq 7.0\text{mm}$

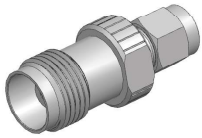

TNC/SMA-KJ

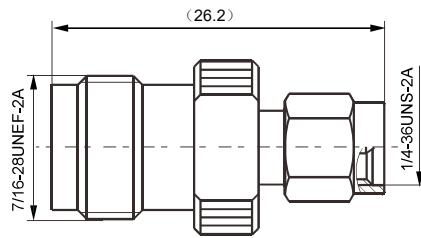

PC BOARD LAYOUT

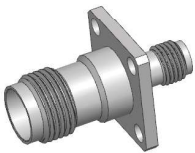
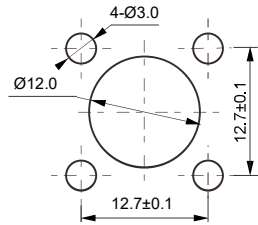

TNC/SMA-KFK

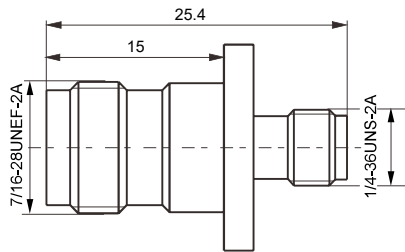

PC BOARD LAYOUT

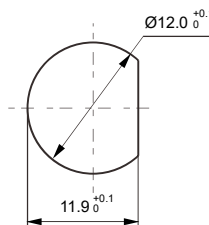

Panel wall size: $\leq 8.4\text{mm}$

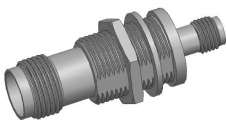

TNC/SMA-KYK

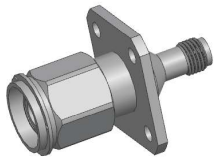

TNC/SMA-JFK

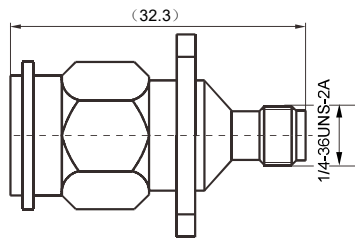

PC BOARD LAYOUT

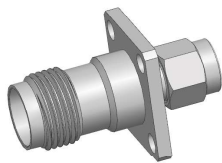
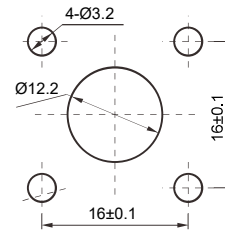

TNC/SMA-KFJ

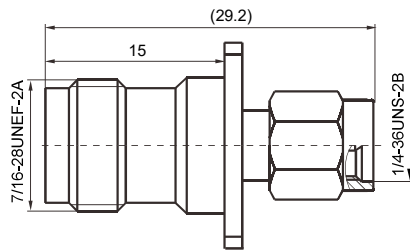

PC BOARD LAYOUT

